

- 1.0 GENERAL NOTES
 1.1 ALL METRIC DIMENSIONS ARE IN BRACKETS [X. X]
 1.2 FOR PATENT INFO: <https://www.cs-pat.com>
 2.0 DESIGN NOTES
 3.0 MANUFACTURING/SPECIAL REQUIREMENTS
 3.1 TIGHTEN ALL BOLTS SECURING FLAT PLATES BY THE TURN-OF-NUT METHOD. TIGHTEN ALL U-BOLTS USING TURN-OF-NUT METHOD WITH ATTENTION TO LEAVE EQUAL DISTANCE AND EQUAL FORCE ON EACH LEG OF THE U-BOLT.
 4.0 TEST
 5.0 PACKAGING
 5.1 PACKAGING SHALL MEET COMMSCOPE REQUIREMENTS PER DOCUMENT IS-PL-3005
 5.2 PRINTED DOCUMENT TO BE PLACED INSIDE POLYBAG AND THEN IN SHIPPING CONTAINER
 5.3 EXTRA HARDWARE MAY BE SUPPLIED, BAGGED AND SHIPPED

REVISIONS			
REV.	DESCRIPTION	DATE	APPROVED
A	INITIAL RELEASE	LS1146 23MAY24	YZ1080 40196349CMO

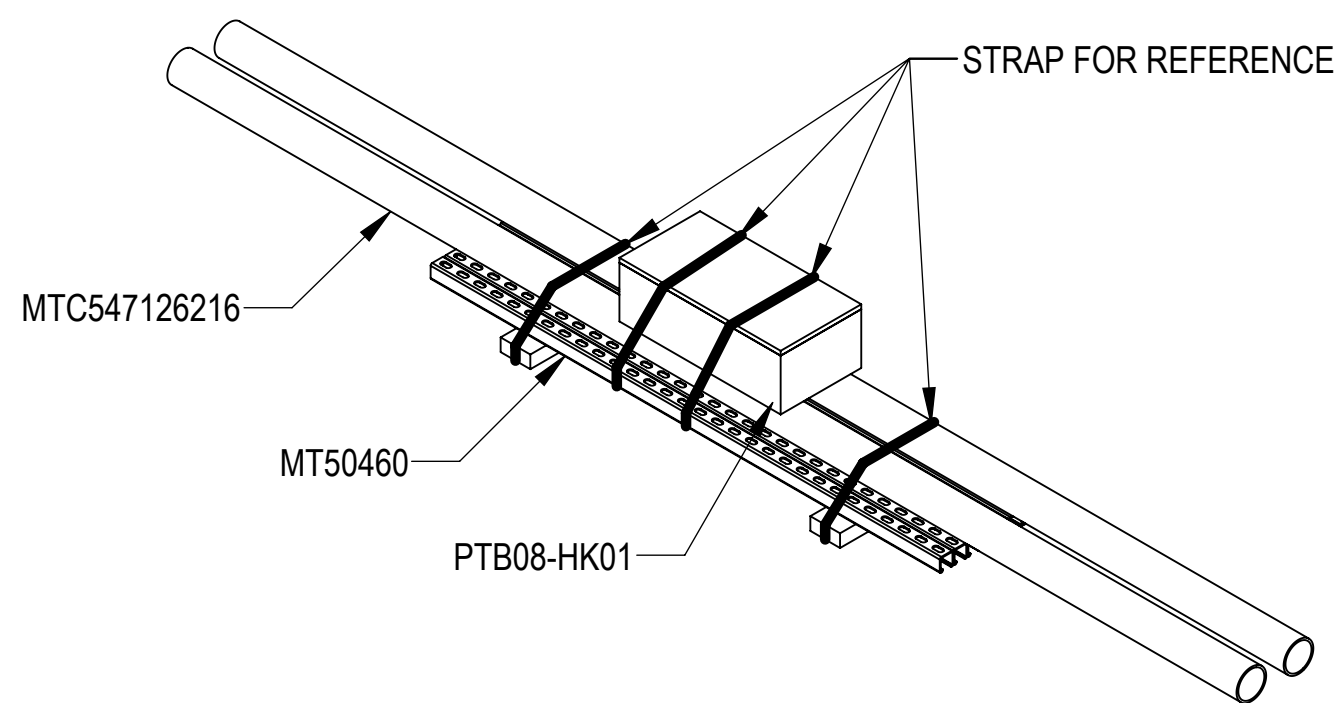
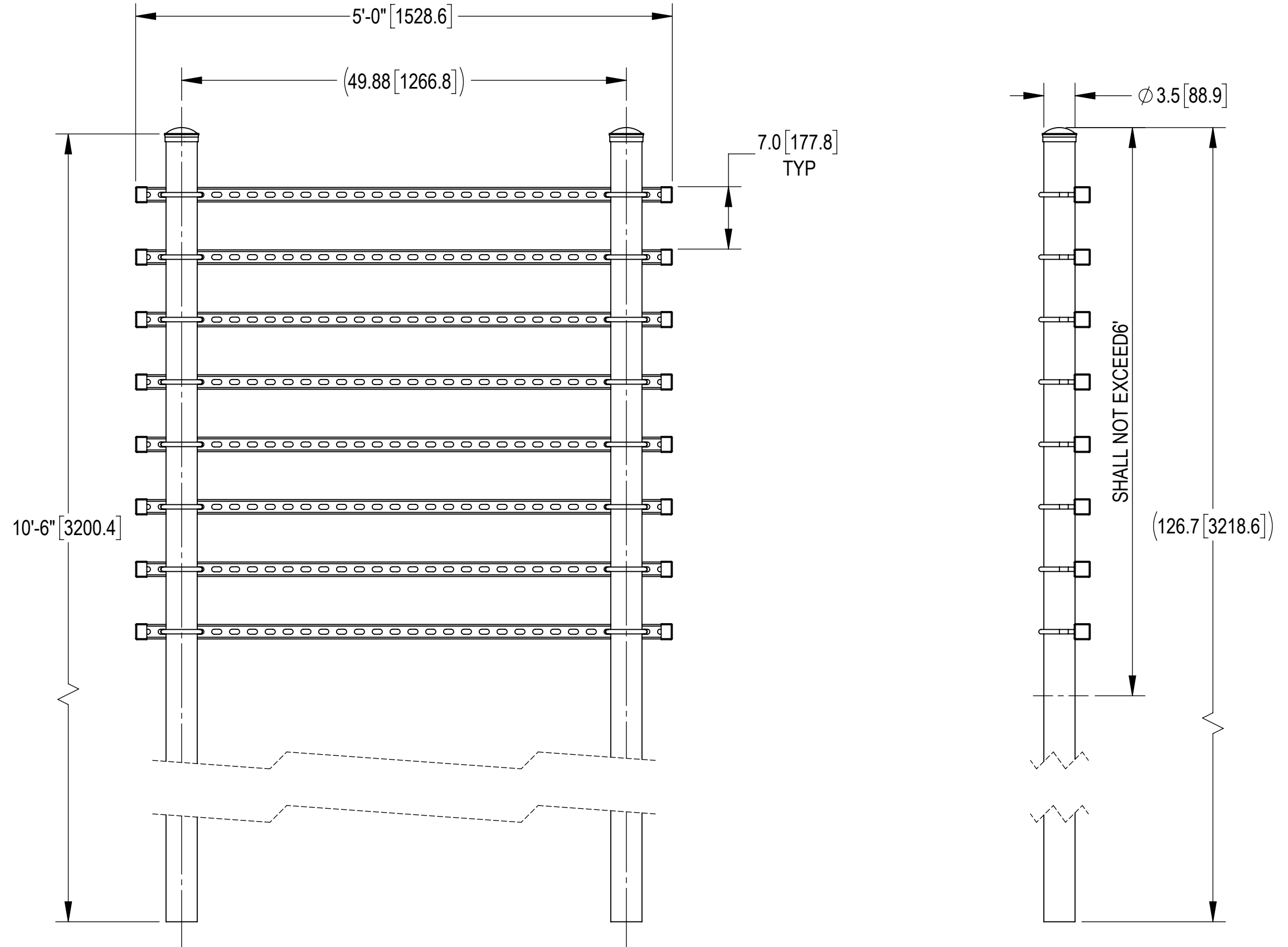
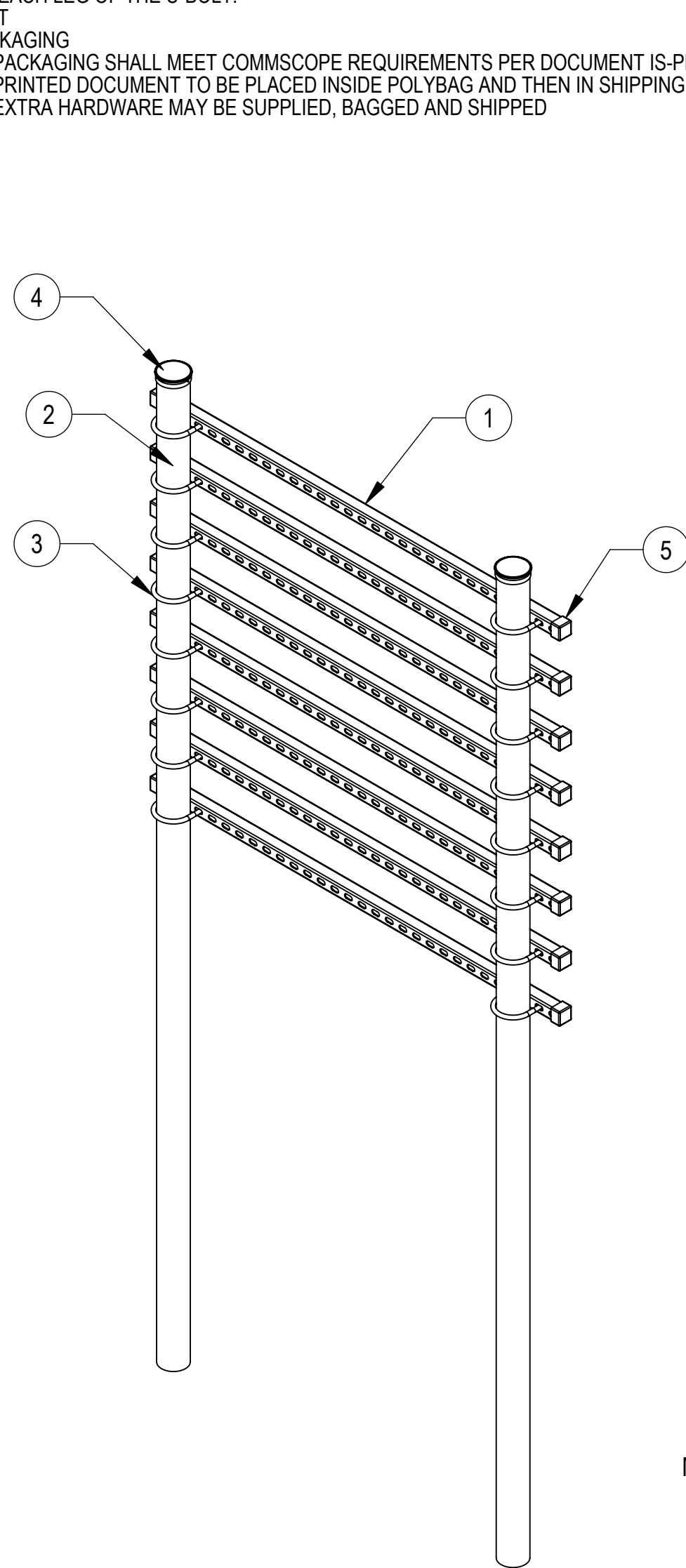

COMPONENT PART NUMBERS PROVIDED FOR ASSEMBLY PURPOSES;
 INDIVIDUAL COMPONENTS MAY BE SHIPPED AS PARTS WITHIN AN INCLUDED KIT.

ITEM	PART NO.	DESCRIPTION	QTY.	WEIGHT	NOTE NO.
1	MT50460	UNISTRUT, SLOTTED, GALV, 1-5/8 SQ X 60"	8	10.17 LBS	
2	MTC547126216	3-1/2"OD X 126" GALV PIPE	2	79.83 LBS	
3	GUB-4355	1/2" X 3-5/8" X 5" GALV U-BOLT	16	0.71 LBS	
4	PC-034	PIPE CAP 3-1/2"	2	0.66 LBS	
5	PTCR01	END CAP	16	0.05 LBS	

PACKING VIEW

DENSITY	257.43	lbs/in ³
MASS	257.43	lbs
VOLUME	918.59	in ³
SURFACE AREA	10994.71	in ²
HEIGHT	3.5"	
LENGTH	126.7"	
WIDTH	60.0"	

COMMSCOPE, INC. OF NORTH CAROLINA

TOLERANCES
 1 PLACE .X[X] ± 0.2[6.3] 3 PLACE .XXX[X] ± 0.060[1.5]
 2 PLACE .XX[X] ± 0.12[3.0] ANGLES ± 2°

SAP MATERIAL MASTER
PT-B-0605-08

FINISH: _____ MATERIAL: _____

NAME	DATE	TITLE
CE LS1146	23MAY24	H-FRAME B 10.5'TALL 5'WIDE 8-RUNGS
RW LS1146	06/04/2024	
AD YMENG	06/04/2024	
RE YMENG	06/04/2024	

SCALE: **1:16** DOCUMENT NO.: **PT-B-0605-08**

SIZE	Auth Group	INSL	MODEL	DRAWING			SHEET		
C			VERSION	STATUS	REVISION	VERSION	STATUS	REVISION	1 OF 1
			00	RE	A	00	RE	A	

UNLESS OTHERWISE SPECIFIED DIMENSIONS ARE IN INCHES INTERPRET PER ANSI Y 14.5M-1994

© 2024 CommScope, Inc. Confidential