

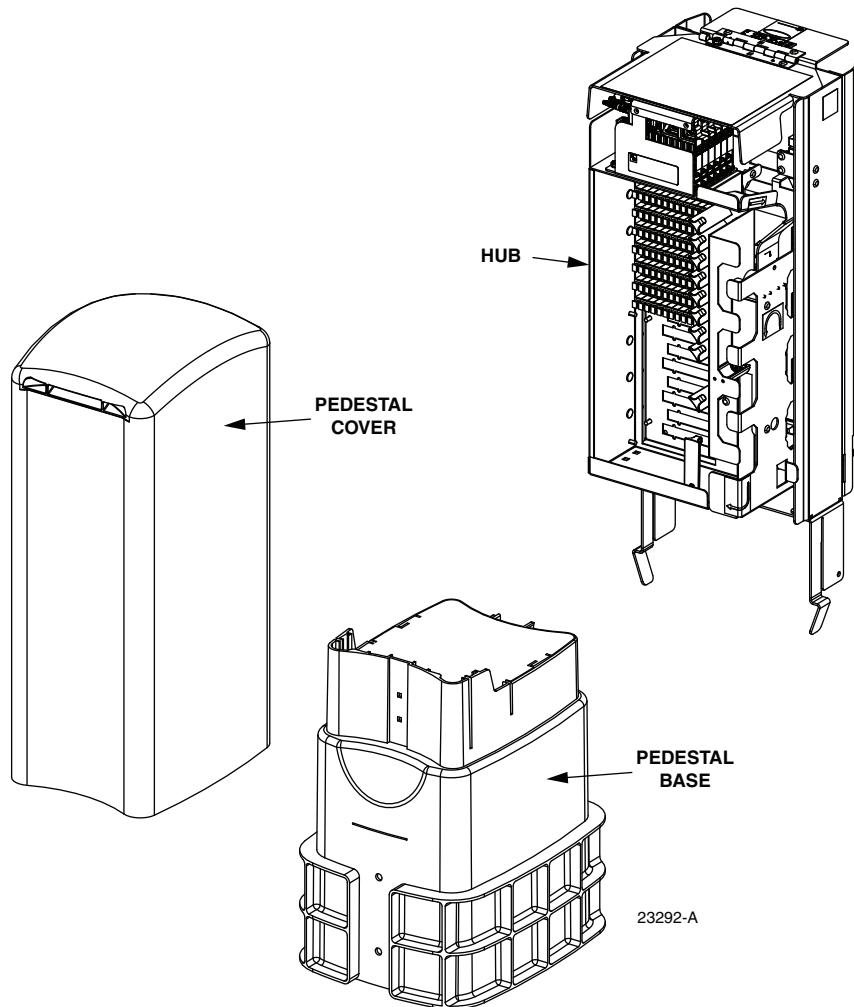

# OmniReach<sup>®</sup> Hub in Pedestal FDH User Manual

ADCP-96-155 • Issue 1 • 4/2009



## COPYRIGHT

© 2009, ADC Telecommunications, Inc.  
All Rights Reserved

## REVISION HISTORY

ISSUE	DATE	REASON FOR CHANGE
1	04/2009	Original

## TRADEMARK INFORMATION

ADC and OmniReach are registered trademarks of ADC Telecommunications, Inc.  
OptiTap is a registered trademark of Corning Cable Systems Brands, Inc.

## DISCLAIMER OF LIABILITY

Contents herein are current as of the date of publication. ADC reserves the right to change the contents without prior notice. **In no event shall ADC be liable for any damages resulting from loss of data, loss of use, or loss of profits and ADC further disclaims any and all liability for indirect, incidental, special, consequential or other similar damages. This disclaimer of liability applies to all products, publications and services during and after the warranty period.**

This publication may be verified at any time by contacting ADC's Technical Assistance Center at 1-800-366-3891, extension 73475 (in U.S.A. or Canada) or 952-917-3475 (outside U.S.A. and Canada), or by e-mail to connectivity\_tac@adc.com.



ADC Telecommunications, Inc.  
P.O. Box 1101, Minneapolis, Minnesota 55440-1101  
In U.S.A. and Canada: 1-800-366-3891  
Outside U.S.A. and Canada: (952) 938-8080  
Fax: (952) 917-1717

## TABLE OF CONTENTS

Content	Page
<b>ABOUT THIS MANUAL</b> .....	<b>v</b>
<b>RELATED PUBLICATIONS</b> .....	<b>v</b>
<b>ADMONISHMENTS</b> .....	<b>v</b>
<b>GENERAL SAFETY PRECAUTIONS</b> .....	<b>v</b>
<b>STANDARDS CERTIFICATION</b> .....	<b>vi</b>
<b>LIST OF ACRONYMS AND ABBREVIATIONS</b> .....	<b>vi</b>
<b>1 DESCRIPTION</b> .....	<b>1</b>
1.1 Hub in Pedestal FDH .....	<b>1</b>
<b>2 BEFORE STARTING THE INSTALLATION</b> .....	<b>4</b>
2.1 Installation Overview .....	<b>4</b>
2.2 Unpacking and Inspection .....	<b>5</b>
2.3 OSP Cable and Pedestal Grounding .....	<b>5</b>
2.4 Installation Hardware .....	<b>5</b>
2.5 Tools and Materials Required for Installation .....	<b>6</b>
<b>3 INSTALLING PEDESTAL</b> .....	<b>6</b>
3.1 Grounding Wire Connection To Pedestal .....	<b>6</b>
<b>4 FEEDER CABLE INSTALLATION AND SPLICING</b> .....	<b>7</b>
4.1 Feeder Cable Installation .....	<b>8</b>
4.2 Grounding Cables with Metallic Members .....	<b>10</b>
4.3 Splicing the Feeder Cable Fibers to the Splitter Fibers .....	<b>11</b>
<b>5 DISTRIBUTION CABLE INSTALLATION AND SPLICING</b> .....	<b>15</b>
5.1 Distribution Cable Installation .....	<b>15</b>
5.2 Splicing the Distribution Cable Fibers to the Distribution Adapters .....	<b>17</b>
<b>6 PLUG AND PLAY SPLITTER MODULE INSTALLATION</b> .....	<b>23</b>
<b>7 ROUTING AND CONNECTING THE SPLITTER OUTPUT FIBERS</b> .....	<b>25</b>
7.1 Storing The Splitter Output Fibers .....	<b>26</b>
7.2 Enabling Service To a Subscriber .....	<b>27</b>
<b>8 SPLITTER COMPARTMENT PASS-THROUGH ROUTING PROCEDURE</b> .....	<b>27</b>
<b>9 ADDING DISTRIBUTION CAPACITY TO AN EXISTING PEDESTAL</b> .....	<b>29</b>
<b>10 INSTALL LOCAL CUSTOMER DROPS</b> .....	<b>30</b>
<b>11 MAINTENANCE AND REPAIR PROCEDURES</b> .....	<b>33</b>
11.1 Distribution Row Adapter Replacement .....	<b>33</b>
11.2 Splitter Compartment Adapter Replacement .....	<b>34</b>
11.3 Replacing a Damaged Fiber or Connector .....	<b>35</b>
<b>12 GROUNDING SYSTEM TERMINAL ACCESS PROCEDURE</b> .....	<b>36</b>
<b>13 CUSTOMER INFORMATION AND ASSISTANCE</b> .....	<b>38</b>

## TABLE OF CONTENTS

---

Content	Page
---------	------

---

*Blank*

## ABOUT THIS MANUAL

This publication describes the OmniReach Hub in Pedestal FDH. Also included are procedures for placing the pedestal, installing and splicing distribution and feeder cables, installing splitter modules, storing the splitter output fibers, connecting the splitter output fibers to the distribution fibers, and replacing damaged components.

► **Note:** Ship along items can be found in a cardboard box packed in the pedestal base.

## RELATED PUBLICATIONS

Listed below are related manuals and their publication numbers. Copies of these publications can be ordered by contacting the ADC Technical Assistance Center at 1-800-366-3891, extension 73475 (in U.S.A. or Canada) or 1-952-917-3475 (outside U.S.A. and Canada).

Title	ADCP Number
Optical Fiber Connector Wet and Dry Cleaning Instructions	<b>90-159</b>
FDH 3000 Cabinet Plug And Play Splitter Installation Instructions	<b>96-087</b>

## ADMONISHMENTS

Important safety admonishments are used throughout this manual to warn of possible hazards to persons or equipment. An admonishment identifies a possible hazard and then explains what may happen if the hazard is not avoided. The admonishments — in the form of Dangers, Warnings, and Cautions — must be followed at all times. These warnings are flagged by use of the triangular alert icon (seen below) and are listed in descending order of severity of injury or damage and likelihood of occurrence.



**Danger:** *Danger is used to indicate the presence of a hazard that **will** cause severe personal injury, death, or substantial property damage if the hazard is not avoided.*



**Warning:** *Warning is used to indicate the presence of a hazard that **can** cause severe personal injury, death, or substantial property damage if the hazard is not avoided.*



**Caution:** *Caution is used to indicate the presence of a hazard that **will** or **can** cause minor personal injury or property damage if the hazard is not avoided.*

## GENERAL SAFETY PRECAUTIONS



**Warning:** *Wet conditions increase the potential for receiving an electrical shock when installing or using electrically-powered equipment. To prevent electrical shock, never install or use electrical equipment in a wet location or during a lightning storm.*



**Danger:** *Do not look into the ends of any optical fiber. Exposure to laser radiation may result. Do not assume the laser power is turned-off or that the fiber is disconnected at the other end.*



**Warning:** *Before digging, check with all local utilities for the presence of buried cables or pipes. Contact with underground cables or pipes, especially electric power cables and gas service lines, could interrupt local utility service and cause serious personal injury and extensive property damage.*

## STANDARDS CERTIFICATION

**Telcordia:** This equipment complies with the applicable sections of GR-2898-CORE (Issue 2, December 1999)

## LIST OF ACRONYMS AND ABBREVIATIONS

The acronyms and abbreviations used in this manual are detailed in the following list:

<b>AWG</b>	American Wire Gauge
<b>C</b>	Centigrade
<b>F</b>	Fahrenheit
<b>FDH</b>	Fiber Distribution Hub
<b>FTTP</b>	Fiber To The Premises
<b>HIP</b>	Hub In a Pedestal
<b>OSP</b>	Outside Plant
<b>PNP</b>	Plug and Play

## 1 DESCRIPTION

This section provides a description of the OmniReach Hub in Pedestal FDH plus the specifications. Though out this document the splice tray side of the pedestal is considered the back (rear).

### 1.1 Hub in Pedestal FDH

The outdoor Hub in Pedestal FDH is a secure fiber optic distribution pedestal that is designed to hold the various optical components required for Fiber To The Premises (FTTP) distribution network applications. The current version of the pedestal is designed for operational efficiency and scalability. This unit is enclosed in a pedestal rather than in a metal cabinet and can be placed in the ground without pouring a concrete pad or installing a hand hole. A typical pedestal is shown in [Figure 1](#).

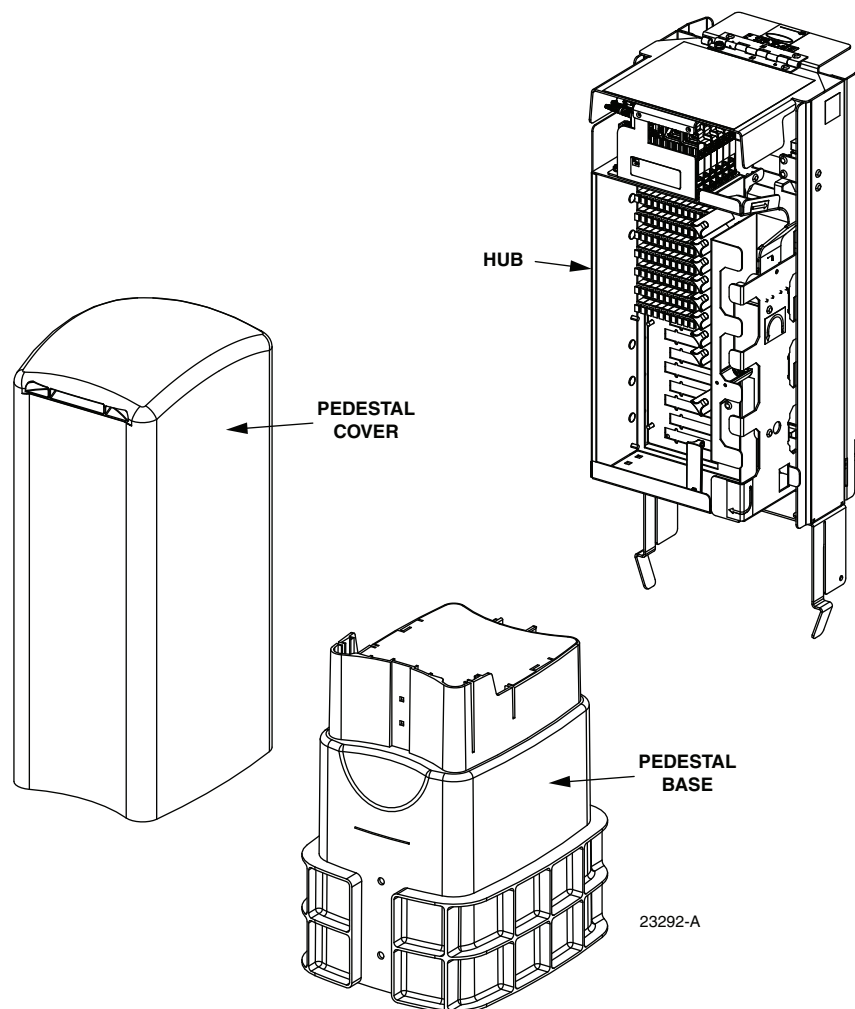

Figure 1. Typical Hub In Pedestal FDH

The pedestal is currently offered in a splice configuration for both the feeder and distribution type cables. Distribution cables and feeder cables may be dielectric or include metallic elements. Ground terminals are provided within the pedestal

The feeder and distribution cables enter/exit the pedestal from the bottom. A clamp secures each cable to the inside of the pedestal. One feeder splice tray is provided and up to four distribution splice trays may be ordered to match the distribution fiber count. Ribbon cable splice trays or stranded cable splice trays may be specified.

The interior of the Hub in Pedestal FDH consists of the following primary components.

**Distribution Rows:** Provide a point for connecting the splitter output fibers with the terminated distribution cable fibers. Each pedestal provides mounting spaces (eight rows of twelve) for up to 96 bulkhead adapters.

**Storage Panel:** Provides a temporary “parking lot” for unused splitter output fibers. Each splitter module is equipped with 8-position connector packs. Up to eight 8-packs can be mounted in the parking lot storage panel.

**Radius Limiters:** Provide a place for storing excess slack from the splitter output fibers.

**Splitter Compartment:** Provides a place for mounting the splitters. Will support up to six splitters. Unused splitter slots can be used for pass-through fibers. The splitters specified for use with the Hub in Pedestal FDH are equipped with bend-optimized fibers.

**Local Customer Drop Adapters:** These adapters are for the connectorized drop cable option and are provided in the Drop Kit.

**Feeder Cable Splice Tray Storage:** Provides storage space for one 5 x 11.75 inch rectangular splice tray when the feeder cable fibers are spliced to the splitter input pigtails. Will accommodate ribbon cable splice tray or stranded cable splice tray. Each splice tray provides storage space for up to 24 splices.

**Distribution Cable Splice Tray Storage:** Provides storage space for up to four 5 x 11.75 inch rectangular splice trays when the distribution cable fibers are spliced to the distribution pigtails. Will accommodate ribbon cable splice trays or stranded cable splice trays. Each splice tray provides storage space for up to 24 splices.

**Ground Lugs** – Provides a point for grounding OSP cables with metallic components.

**Cable Clamps** – Used to secure cables inside the pedestal.

**Moisture/Rodent Barrier Plate** – Located at the top of the pedestal base. Used to limit moisture in the pedestal and deter rodents from entering the pedestal.



Access to the pedestal requires a 216B key tool (accessory) to release the latch. The specifications for the Hub in Pedestal FDH are provided in [Table 1](#) and [Table 2](#).

**Table 1. Hub in a Pedestal FDH Specifications**

PARAMETER	SPECIFICATION
<b>Pedestal</b>	
Dimensions (H x W x D) See <a href="#">Figure 2</a>	45 x 14.5 x 11.5 inches (114.3 x 36.8 x 29.2 cm)
Weight (includes enclosure)	39.5 lbs (18 kg)
Distribution ports	12, 24, 36, 48, 60, 72, or 96
Distribution port adapters/connectors	APC/SC
Splitter compartment splitter capacity	6 splitters
Feeder fiber capacity	6 or 12 fibers
Splitter output fiber storage panel capacity	64 connectors with 8-pack storage modules
Distribution splice tray storage capacity	Up to 4
Feeder splice tray storage capacity	1
Splice tray splice capacities Stranded cable splice trays Ribbon cable splice trays	Up to 24 splices per tray Up to 24 splices per tray
<b>Splitter Modules</b>	
Splitter module output fibers	Bend-optimized fiber terminated with APC/SC connectors
Test bandpass	1260–1360 nm, 1480–1500 nm, 1550–1560 nm
Overall bandpass	1260–1625 nm
Return loss at test bandpass	≥55 dB

**Table 2. Splitter Insertion Loss at test Band Pass**

SPLITTER TYPE	MAXIMUM LOSS (dB) *	
	SPLITTER	w/SCAPC**
1 x 2	3.7	4.3
1 x 4	7.2	7.8
1 x 8	10.3	10.9
1 x 16	13.5	14.1
1 x 32	16.7	17.3
1 x 64	20.4	21
2 x 16	14.1	14.7
2 x 32	17.4	18

\* – Specification includes the loss from the input and output connectors.  
\*\* – PNP splitters with a 0.3 dB per connector (APC)

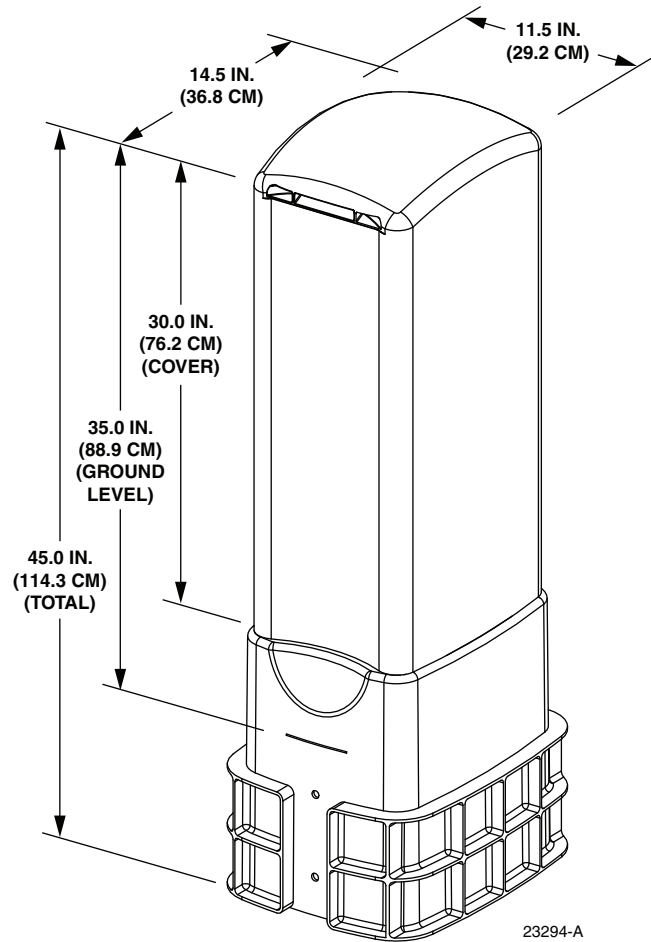

**Figure 2. Hub in Pedestal FDH Dimensions**

## 2 BEFORE STARTING THE INSTALLATION

This section provides general installation considerations, unpacking and inspection procedures, and lists the tools and materials required for Hub in Pedestal FDH installation. Make certain that full access is available all the way around the pedestal at the location where it is to be installed.

### 2.1 Installation Overview

Installation of the Hub in Pedestal FDH involves the following main tasks:

**Securing Pedestal** – The pedestal must be secured to the ground.

**Feeder Cable Installation** – A customer-supplied feeder cable must be routed into the pedestal base and spliced to the splitter compartment input pigtails.

**Distribution Cable Installation** – Customer-supplied distribution cables must be routed into the pedestal base and spliced to the distribution pigtails.

**Install FDH onto Base** – After installing and leveling pedestal base, slide FDH into base.

**Splitter Installation** – The pedestal may be ordered with no splitters, one splitter, or two splitters. If splitters are ordered with the pedestal, they are shipped separately and packed in a box that is placed in the pedestal base for shipping. If additional splitters are required, they must be ordered separately. All splitter modules must be installed in the splitter compartment on site.

**Splitter Output Fiber Connections** – Service is enabled by connecting the splitter output fiber connectors to the subscriber distribution ports. Unused output fibers are temporarily “parked” in the storage panel until they are needed for service.

## 2.2 Unpacking and Inspection

► **Note:** Ship along items (splitters, cable clamps, etc.) can be found packed in the pedestal base.

This section provides instructions for opening the shipping boxes, verifying that all parts have been received, and verifying that no shipping damage has occurred.

Use the following procedure to unpack and inspect the pedestal and all accessories:

1. Open the shipping carton(s) and carefully unpack the pedestal and any accessories from the protective packing material.
2. Remove packing material from pedestal base and remove ship along items.
3. Open the pedestal (requires 216B key tool) and check for broken or missing parts. If there are damages, contact ADC (see [Section 13](#)) for an RMA (Return Material Authorization) and to reorder if replacement is required.

## 2.3 OSP Cable and Pedestal Grounding

The pedestal frame provides a common ground that is used to tie together all the components of the pedestal that must be grounded. The pedestal itself and any OSP cables with metallic members must be connected to an earth ground source.

## 2.4 Installation Hardware

Various parts for cabling, securing, and grounding the pedestal are shipped or purchased separately. Verify that the items in [Table 3](#) are available.

**Table 3. Pedestal Installation Hardware**

ITEM
Mounting stake (optional)
Cable clamp grommets
Moisture barrier plate
Additional cable clamp kits (if configured)
Splitter (if configured)

## 2.5 Tools and Materials Required for Installation

The following tools and additional materials are required for pedestal installation:

- 216B key tool (accessory - required to open pedestal cover)
- Screwdriver (flat blade)
- Shovel
- Hammer
- Pliers
- Wire cutter
- Utility knife
- Tape measure
- Pen or marker
- Splicing equipment
- Grounding system, copper wire, ground rod, and grounding clamp (per local requirements)

## 3 INSTALLING PEDESTAL

Always install pedestal following local practices, the list below is just a general guide to the process:

- Determine location for pedestal installation
- Trench in feeder and distribution cables
- Dig hole for pedestal so that the bottom surface is 10-inches (25.4 cm) below the final grade
- Position pedestal base in hole
- Push feeder and distribution cables into the base of the pedestal and through the moisture/rodent barrier plate located at the top of the pedestal base
- If required install mounting stake
- If required install ground rod and route ground wire into pedestal base per local practices
- Backfill and level soil around pedestal
- Tamp earth around pedestal so it is level with surrounding landscape
- Slide FDH into base, until it locks in place

### 3.1 Grounding Wire Connection To Pedestal

A grounding lug is provided with the pedestal for connecting a #6 copper grounding wire to the interior of the pedestal. Use the following procedure to install the grounding wire:

1. Working from the back side of the pedestal, locate the bottom grounding lug see [Figure 3](#).
2. Obtain a length of #6 AWG copper wire for use as a grounding wire.
3. If not already in place, install rodent/moisture barrier plate into the top of the pedestal base.

4. Insert one end of the grounding wire into the pedestal grounding lug. Tighten the grounding lug set screw to 30 to 35 lbs force-inches (3.4 to 4.0 Nm) of torque.
- ▶ **Note:** The grounding lug provided with the pedestal can be used for #6 – #14 AWG wire.
5. Route the free end of the grounding wire through the rodent barrier to an approved earth ground source (ground rod).
  6. Cut the grounding wire to length and connect it to the earth ground source as specified by local code or practice.

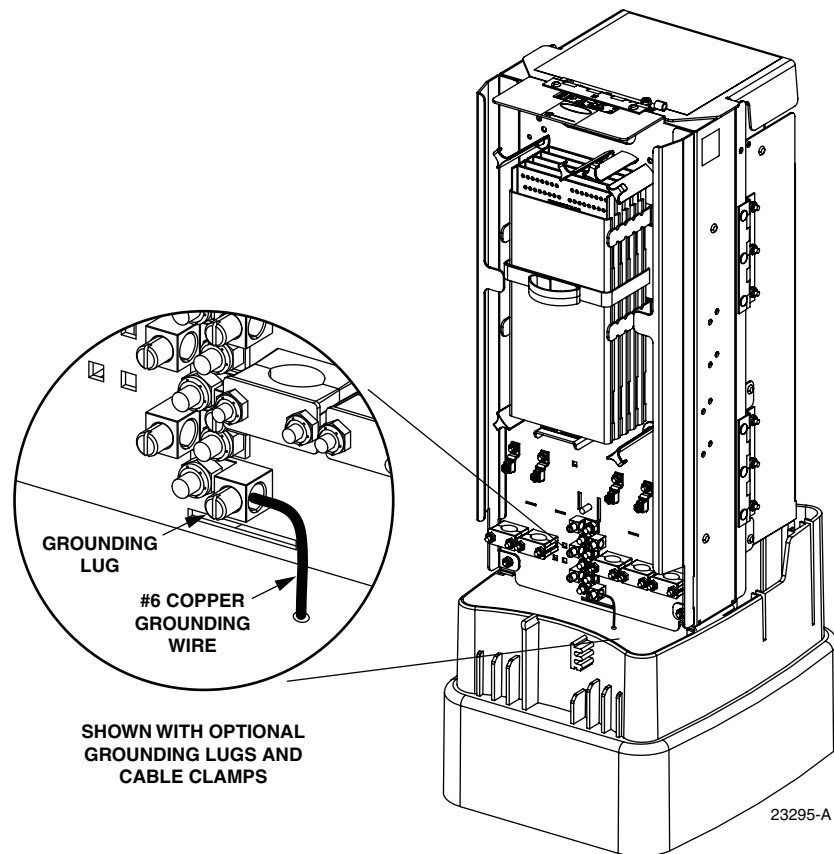

**Figure 3. Grounding Wire Connection To Pedestal**

#### **4 FEEDER CABLE INSTALLATION AND SPLICING**

This section describes how to install the OSP feeder cable in the Hub in Pedestal FDH. Also covered are procedures for splicing the feeder cable fibers to the splitter input pigtails.

## 4.1 Feeder Cable Installation

The feeder cable enters/exits the pedestal from the bottom. A clamp secures the cable to the inside of the pedestal. Beyond the clamp, the outer sheath of the cable is removed to expose the optical fibers. The feeder cable is typically a 6- or 12-fiber OSP cable with stranded fiber or ribbon fiber construction. Breakout kits should be installed on ribbon cable to protect the exposed optical fibers and grounding kits should be installed on all cables with metallic elements. From the clamping point, the optical fibers are routed to splice trays for splicing to the splitter input pigtails.

Use the following procedure to install the feeder cable:

1. Locate the cable entry/exit point that is specified for feeder cable installation as shown in [Figure 4](#).

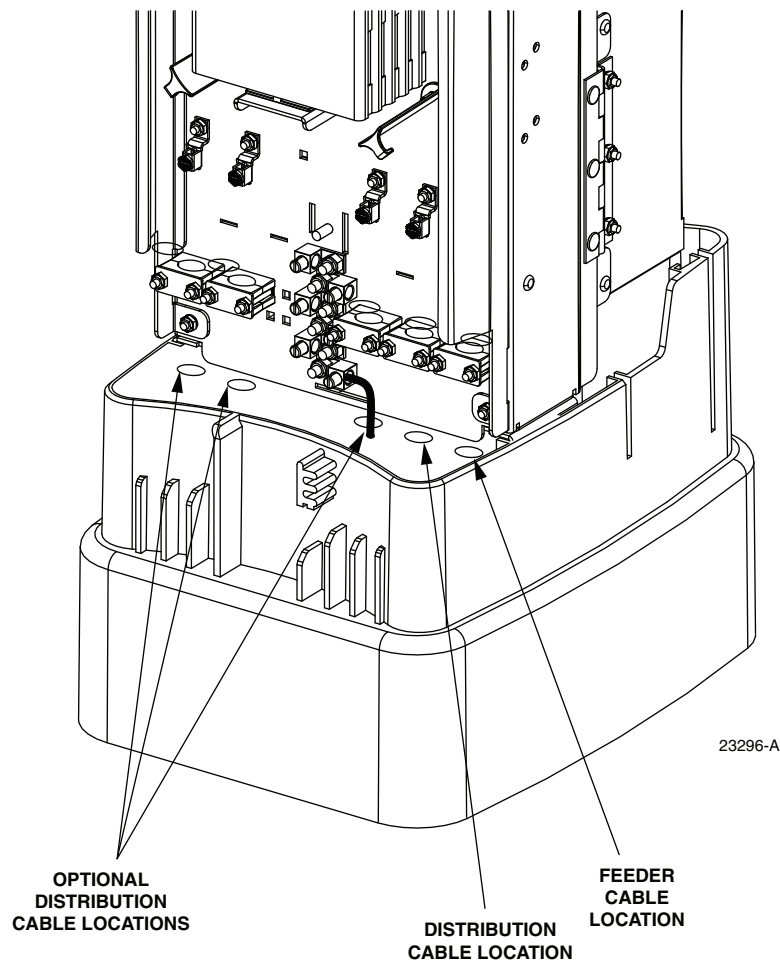

**Figure 4. Cable Entry/Exit Holes**

2. Push feeder cable through the entry/exit hole in the rodent/moisture barrier plate located at the top of the pedestal base and pull through about **12 feet (3.7m)** of cable slack.

3. Strip back the feeder cable sheath **145 inches (3.7m)** to expose the fiber subunits or fiber ribbons.
  4. Install breakout and grounding kits as required by local practice. Follow the installation instructions provided with each kit.
- **Note:** A breakout kit is recommended when installing OSP ribbon cable. The breakout kit includes plastic tubes that protect the fiber ribbons and prevent damage. Instructions for trimming the plastic tubes to length are provided in [Section 4.3](#). If a grounding kit is required, install the cable grounding clamp prior to securing the cable to the pedestal.
5. Assemble the cable clamp on the feeder cable as shown in [Figure 5](#).
  6. Use the cable clamp (with grommets if needed) to secure the cable to the inside of the pedestal.

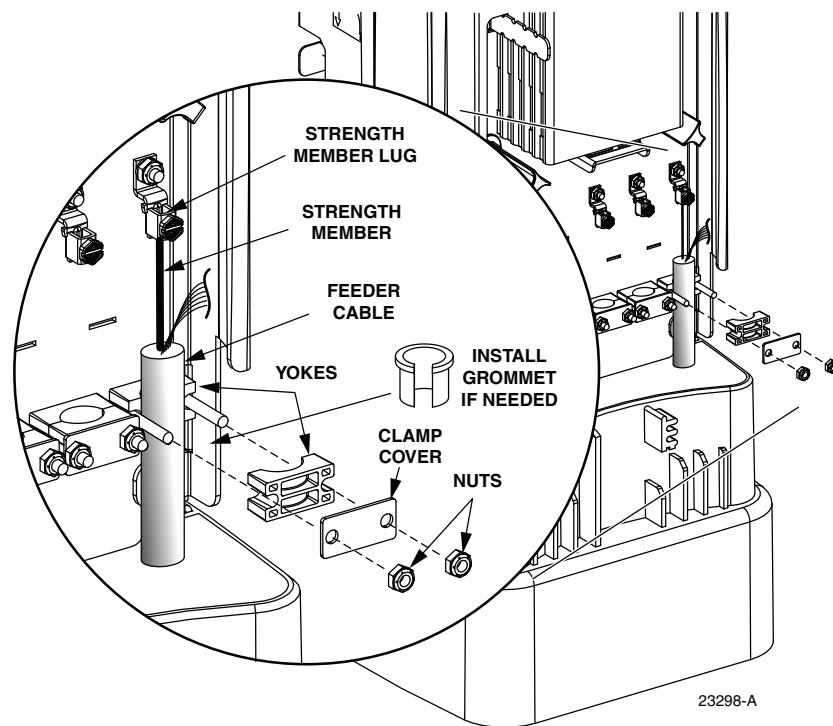

**Figure 5. Assembling Feeder Cable Clamp**

7. Attach strength member to strength member lug.
8. Carefully coil the exposed feeder cable fibers around the back of the pedestal where they will be out of the way until ready to begin splicing.
9. If a grounding kit was installed on the feeder cable, refer to [Section 4.2](#) for connecting the grounding cable to the pedestal ground block. If a grounding kit was not required, refer to [Section 4.3](#) for the splicing procedure.

## 4.2 Grounding Cables with Metallic Members

All pedestals are equipped with locations for grounding OSP cables equipped with metallic shields or strength members. The ground location, shown in [Figure 6](#), provides up to five grounding locations. If a cable requires grounding, connect a #6 stranded copper wire to the metallic components of the cable. Follow the instructions provided with the cable grounding kit to attach the grounding wire to the cable. Use the following procedure to connect the grounding wire to the ground location:

1. Route the cable grounding wire to a grounding location.
2. Insert grounding wire into ground lug as shown in [Figure 6](#).
3. Tighten the ground lug screw to 25 to 30 lbs-force inches (2.8 to 3.4 Nm) of torque.

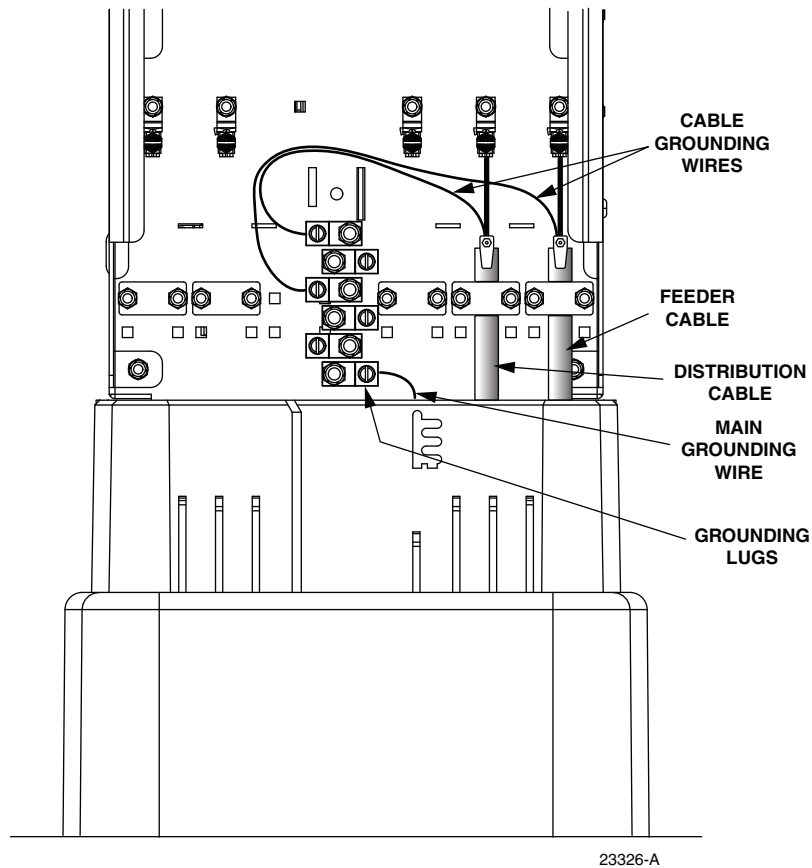

**Figure 6. Location of Cable Grounding Lugs**



### 4.3 Splicing the Feeder Cable Fibers to the Splitter Fibers

A single splice tray for splicing the feeder cable fibers to the splitter fibers is mounted at the back of the pedestal. Use the following procedure to route and splice feeder cables:

1. Locate the feeder splice tray assembly which is mounted at the back of the pedestal, as shown in [Figure 7](#), and locate the splitter input fibers which are routed to the feeder splice tray. The feeder splice tray is always the first tray located closest to the center of the pedestal.
2. Distribution fiber splice trays are installed on top of the feeder splice tray and must be set aside to gain access to the feeder splice tray.
3. Unfasten the hook and pile strips that secure the trays in place and unwind the attached splitter fiber pigtailed from around the splice tray holder.

► **Note:** For stranded fiber or if protective tubing is not required for the fiber ribbons, [Step 4](#), [Step 9](#), and [Step 10](#) of this procedure may be omitted.

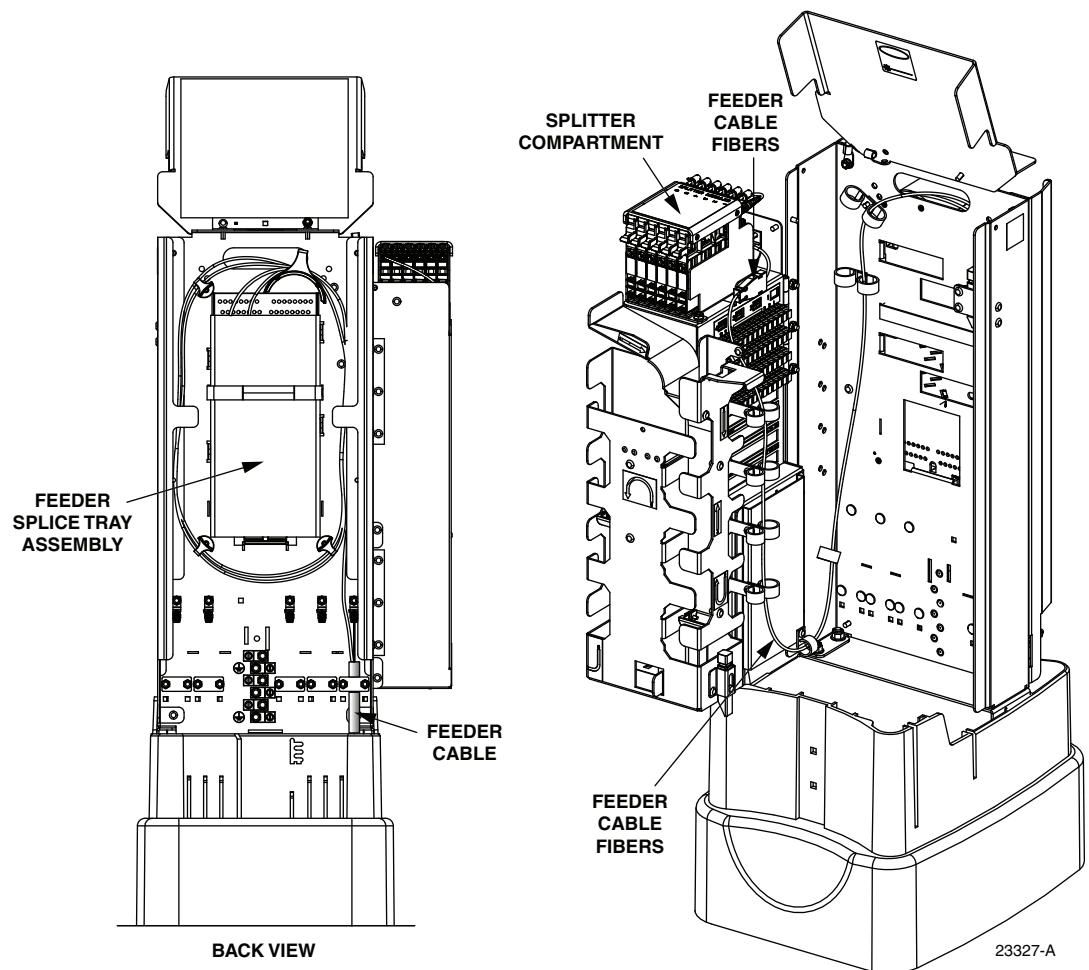

**Figure 7. Feeder Splice Tray and Feeder/Splitter Fiber Routing**

4. For ribbon fiber cables obtain a length of the protective tubing that is provided with the ribbon cable breakout kit and temporarily attach it to the breakout. Do not insert any fibers into the tube at this point.
5. Beginning at the feeder cable breakout point shown in [Figure 8](#), route the protective tube or ribbon subunit to the intersect point with the splitter pigtail.

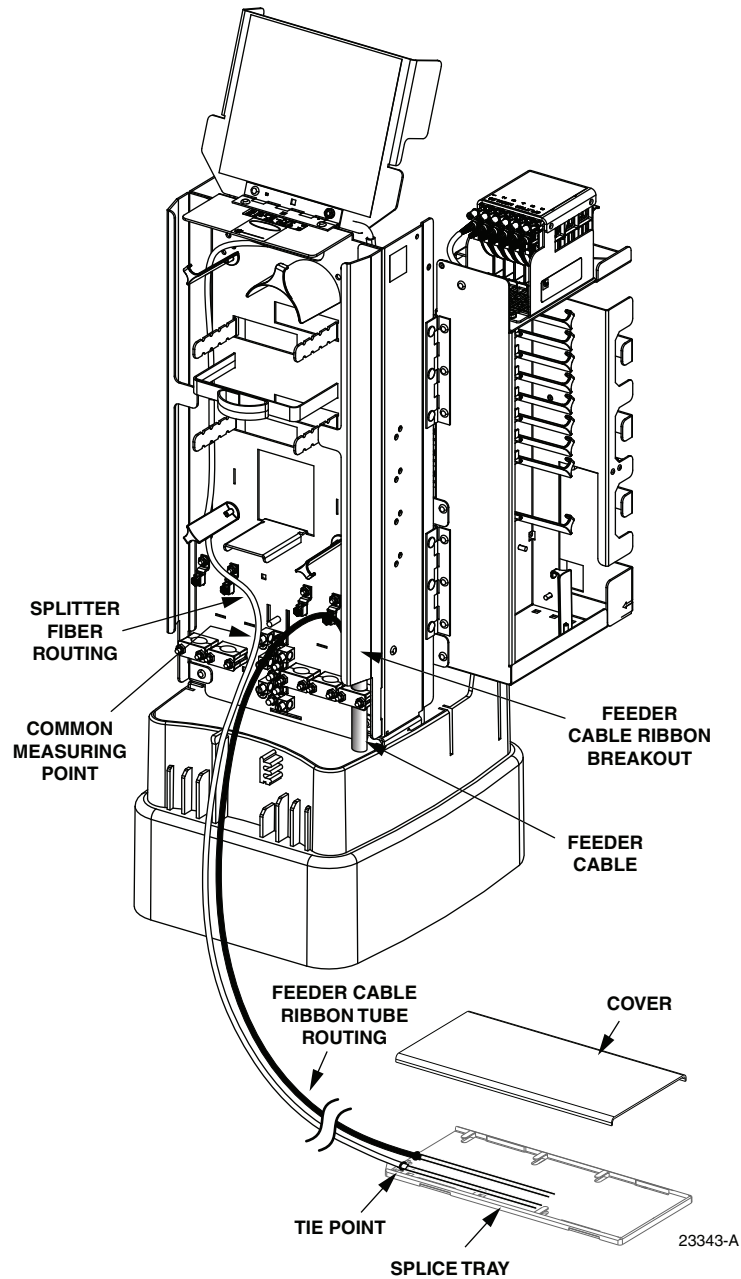

**Figure 8. Feeder Fiber Routing to Splice Tray**



**Caution:** Always allow sufficient fiber length to permit routing without severe bends. Non bend-optimized fibers may be permanently damaged if bent/curved to a radius of less than 1.5 in. (3.81 cm).

6. Create a common measuring point by securing the protective tube or fiber subunit (use lacing or a cable tie) to the splitter pigtail at the intersect point.
7. Route the protective tube or fiber subunit to the splice tray and then remove the clear plastic cover from the splice tray.
8. Cut the protective tube or the fiber subunit tube (don't cut the fibers) to the **same length** as the splitter pigtail fibers attached to the splice tray.
9. When using ribbon fiber, detach the protective tube from the breakout and carefully feed the feeder cable fiber ribbons into the tubing.
10. When using ribbon fiber, re-attach the protective tube to the cable breakout and then re-install tubing as described in [Step 5](#) and [Step 6](#).
11. Use lacing or cable ties to secure the protective tube or fiber subunit to the splice tray and verify that the feeder protective tube is the same length as the attached splitter fiber tubes. Adjust as needed to make the lengths equal.



**Caution:** Improper handling can damage fiber optic cables. Do not over tighten cable ties or lacing as this can cause damage or attenuation. Do not compress the fibers or allow them to kink.

12. From the tie point on the splice tray, trim the **feeder fibers** to a cut length of 42 inches (107 cm) and the **splitter fibers** to a cut length of 36 inches (91 cm).
- **Note:** The ends of feeder pigtails have been ribbonized at the factory for ease of splicing to ribbon cables. If splicing to stranded cable cut the ribbon ends off.
13. Splice the feeder cable fibers to the appropriate splitter fiber pigtails as specified by local policies and procedures. Adjust and route the fibers within the splice tray as shown in [Figure 9](#) or [Figure 10](#). Refer to [Table 4](#) for the splitter fiber designations.

**Table 4. Fiber Port Designations for Feeder Cables**

FIBER	SPLITTER PORT	SPARE PORT	FIBER	SPLITTER PORT	SPARE PORT
1 (Blue)	1	–	7 (Red)	–	7
2 (Orange)	2	–	8 (Black)	–	8
3 (Green)	3	–	9 (Yellow)	–	9
4 (Brown)	4	–	10 (Violet)	–	10
5 (Slate)	5	–	11 (Rose)	–	11
6 (White)	6	–	12 (Aqua)	–	12

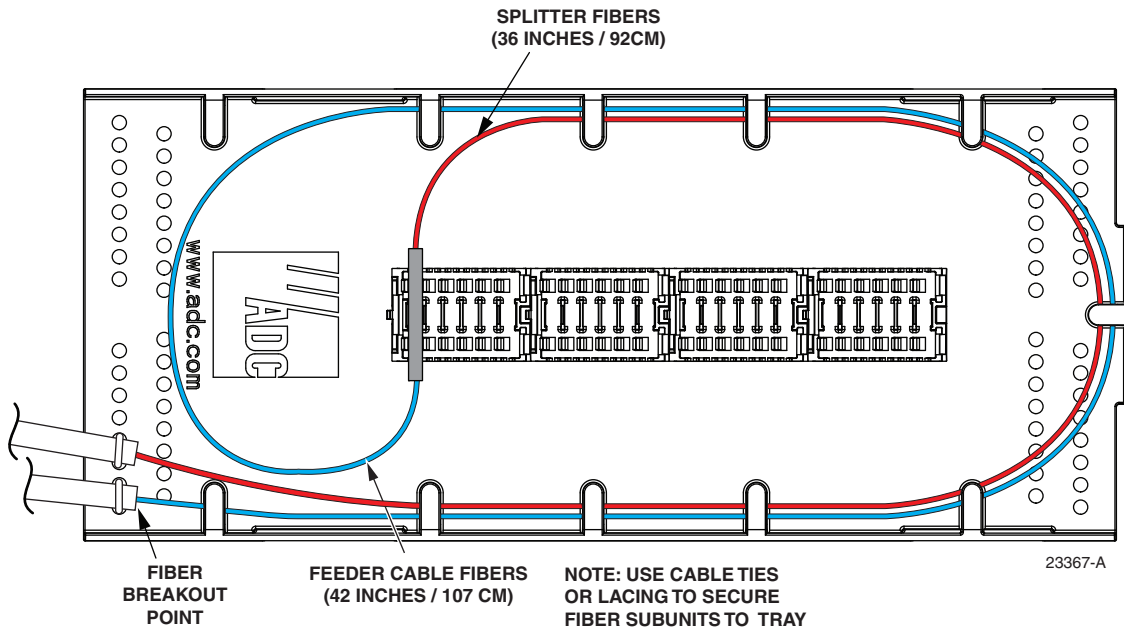

**Figure 9. Ribbon Fiber Splice Tray - Feeder Cable Splicing**

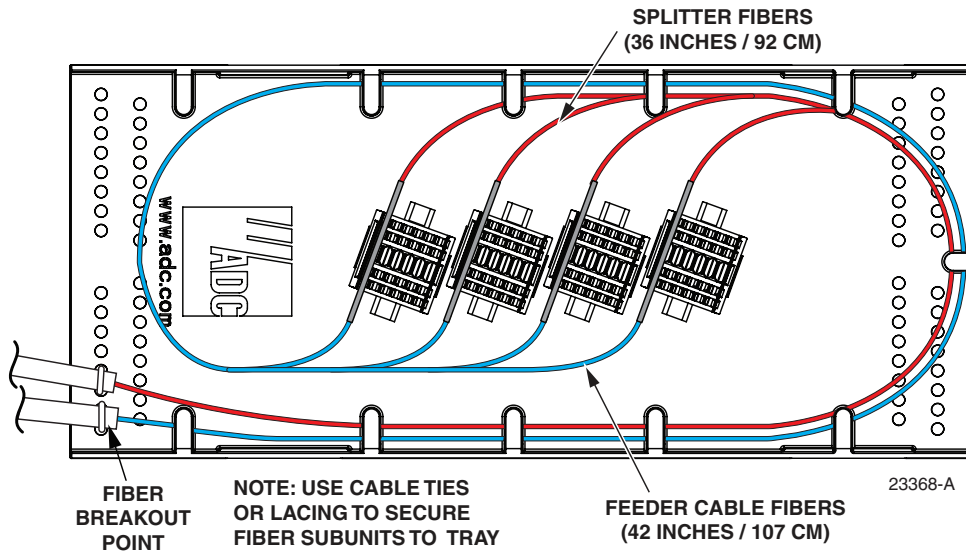

**Figure 10. Stranded Fiber Splice Tray - Feeder Cable splicing (Four shown for clarity.)**

14. After splicing is completed, re-install the clear plastic cover on the splice tray.
15. To reinstall the splice trays, route the attached tubes around the splice tray holder radius limiters (there should be two service loops) as shown in [Figure 11](#). Avoid twisting or kinking the fiber tubes.
16. Secure the splice trays to the splice tray holder using the hook and pile strips.

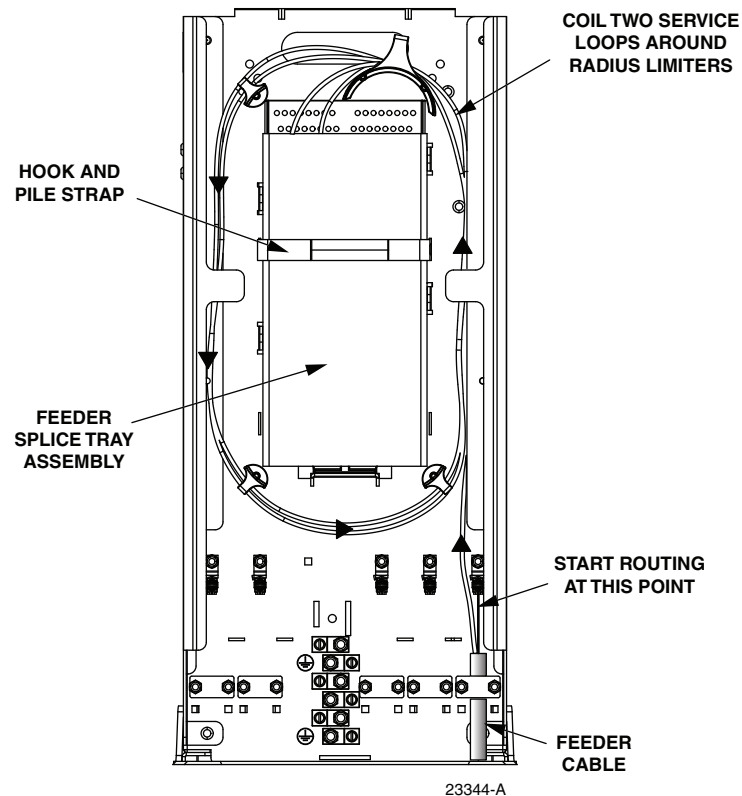

Figure 11. Feeder Splice Tray Replacement

## 5 DISTRIBUTION CABLE INSTALLATION AND SPLICING

This section describes how to install the distribution cables in pedestals. Also covered are procedures for splicing the distribution cable fibers to the distribution fiber adapters.

### 5.1 Distribution Cable Installation

Distribution cables enter/exit the pedestal from the bottom. A clamp secures each cable to the inside of the pedestal. Beyond the clamp, the outer sheath of each cable is removed to expose the optical fibers. The distribution cable is either stranded fiber or ribbon fiber construction. Breakout kits should be installed to protect exposed optical fibers and grounding kits should be installed on cables with metallic elements. From the clamping point, the optical fibers are routed to splice trays for splicing to the distribution fiber adapters.

Use the following procedure to install each distribution cable:

1. Locate the cable entry/exit hole (on bottom of the pedestal) that is specified for distribution cable installation as shown in [Figure 12](#).

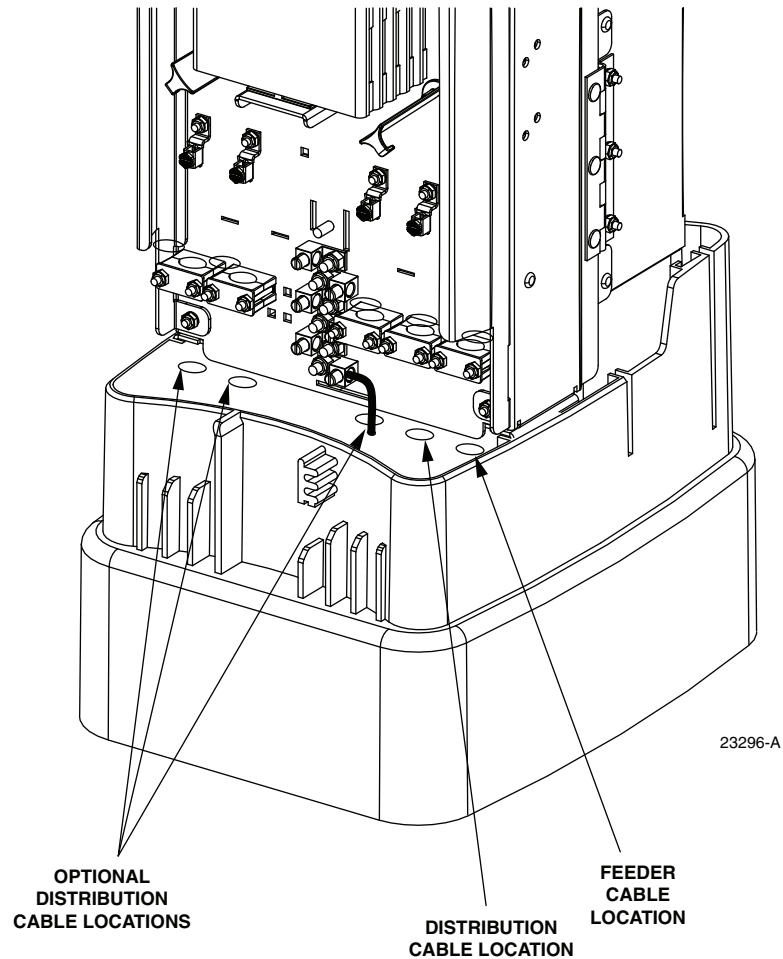
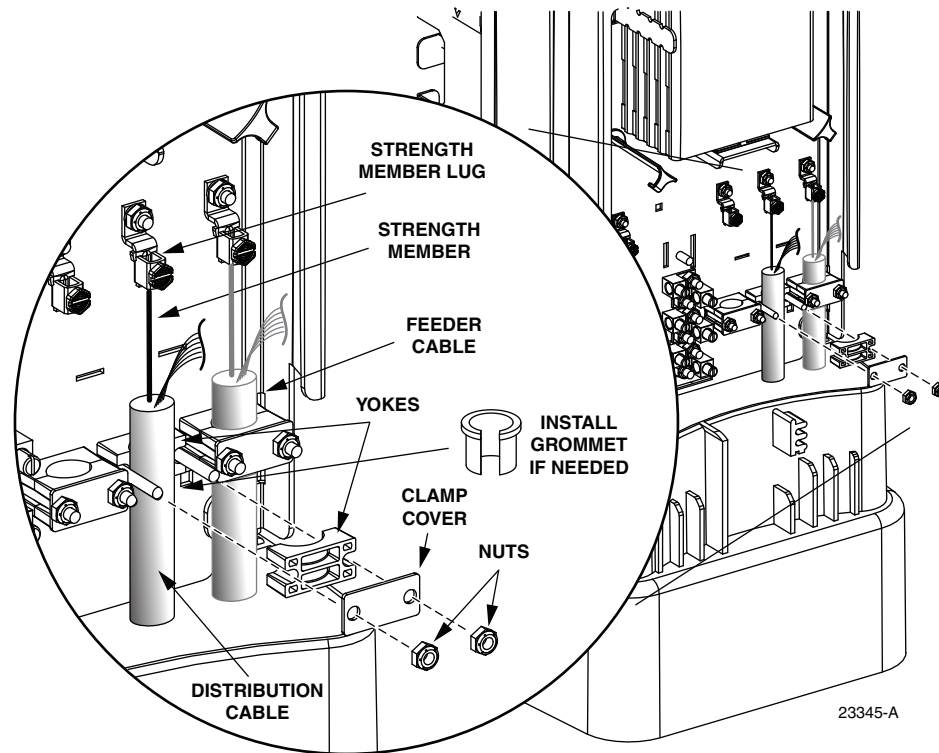

**Figure 12. Cable Entry/Exit Holes**

2. Push distribution cable through the entry/exit hole in the moisture/rodent barrier plate located at the top of the pedestal base and pull through about **12 feet (3.7m)** of cable slack.
3. Strip back the distribution cable sheath **145 inches (3.7m)** to expose the fiber subunits or fiber ribbons.
4. Install breakout and grounding kits as required by local practice. Follow the installation instructions provided with each kit.

► **Note:** A breakout kit is recommended when installing ribbon cable. The breakout kit includes plastic tubes that protect the fiber ribbons and prevent damage. Instructions for trimming the plastic tubes to length are provided in [Section 5.2](#). If a grounding kit is required, install the cable grounding clamp prior to securing the cable to the pedestal.

5. Assemble the cable clamp (provided with pedestal) on the distribution cable as shown in [Figure 13](#).



**Figure 13. Assembling Distribution Cable Clamp**

6. Use the cable clamp (with grommets if needed) to secure the cable to the inside of the pedestal.
7. Attach strength member to strength member lug.
8. Carefully coil the exposed distribution cable fibers around the back of the pedestal where they will be out of the way until ready to begin splicing.
9. If a grounding kit was installed on the distribution cables, refer to [Section 4.2](#) for connecting the grounding cable to the pedestal ground block. If a grounding kit was not required, refer to [Section 5.2](#) for the splicing procedure.

## 5.2 Splicing the Distribution Cable Fibers to the Distribution Adapters

Splice trays for splicing the distribution cable fibers to the distribution fibers are mounted at the back of the pedestal. One splice tray is provided for every two distribution rows. Each fiber splice tray can hold up to 72 mass fusion splices. Use the following procedure to route and splice distribution cables:

1. Locate the distribution splice tray assembly which is mounted at the back of the pedestal, as shown in [Figure 14](#). Trace the routing of the distribution fibers and identify each splice tray and the corresponding distribution ports.

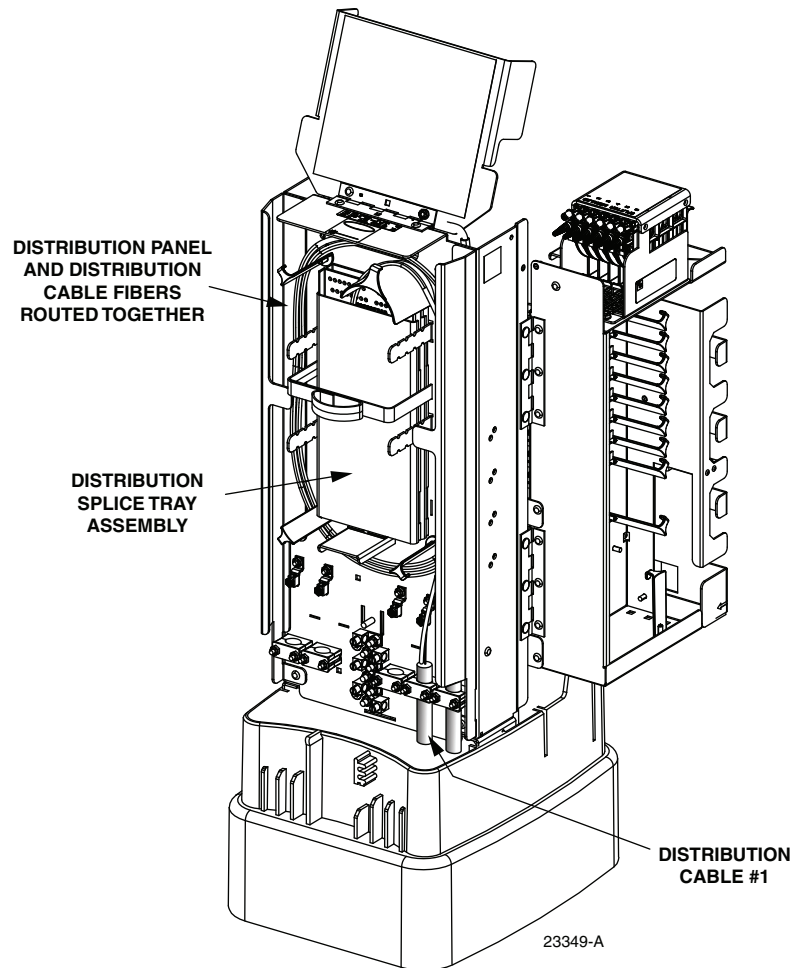
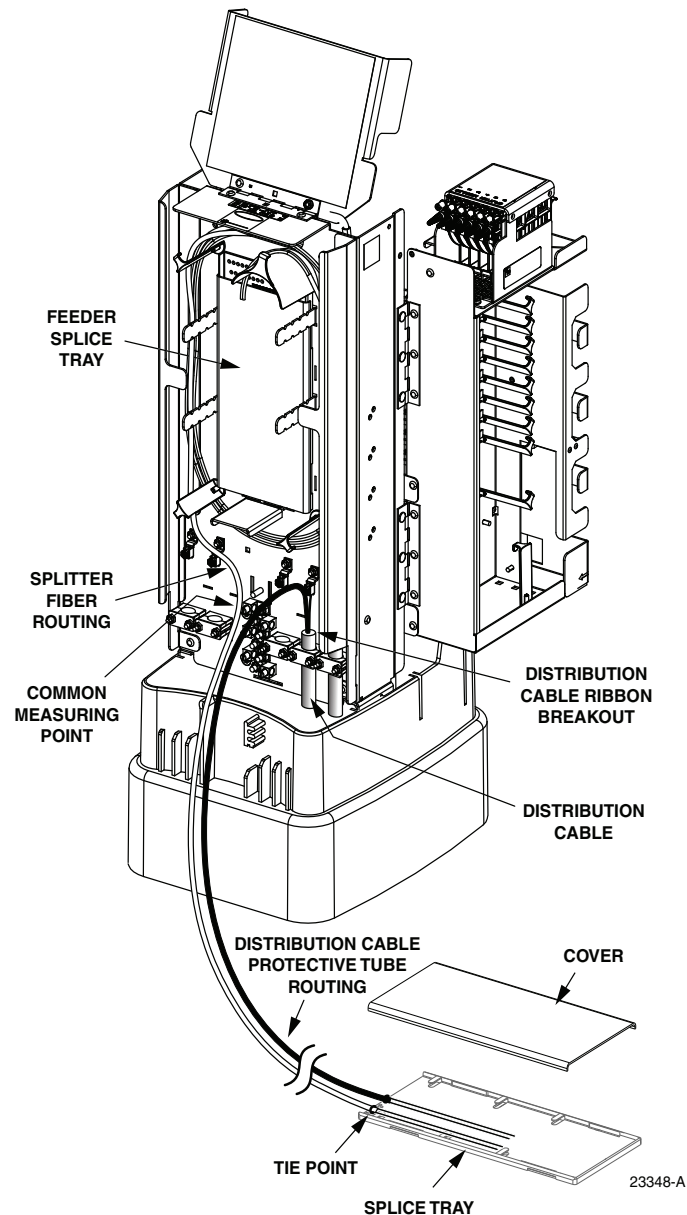

**Figure 14. Distribution Splice Trays and Distribution Port Fiber Routing**

2. Locate the appropriate splice tray for splicing the distribution cable fibers.
  3. Unfasten the hook and pile strips that secure the tray in place and unwind the attached fiber tubes from around the distribution splice tray assembly.
- **Note:** For stranded fiber or if protective tubing is not required for the fiber ribbons, [Step 4](#), [Step 9](#), and [Step 10](#) of this procedure may be omitted.
4. For ribbon fibers obtain a length of the protective tubing that is provided with the ribbon cable breakout kit and temporarily attach it to the breakout. Do not insert any fibers into the tube at this point.



- Beginning at the distribution cable breakout point shown in Figure 15, route the protective tube or ribbon subunit to the intersect point with the distribution pigtails.



**Figure 15. Distribution Fiber Routing**



**Caution:** Always allow sufficient fiber length to permit routing without severe bends. Non bend-optimized fibers may be permanently damaged if bent/curved to a radius of less than 1.5 in. (3.81 cm).

- Create a common measuring point by securing the protective tube or fiber subunit (use lacing or cable ties) to the distribution pigtail at the intersect point.

7. Route the protective tube or fiber subunit to the splice tray and then remove the clear plastic cover from the splice tray.
8. Cut the protective tube or the fiber subunit tube (don't cut the fibers) to the **same length** as the distribution tube attached to the splice tray.
9. When using ribbon fiber, detach the protective tube from the breakout and carefully feed the distribution cable fiber ribbons for the appropriate distribution row into the tubing.
10. When using ribbon fiber, re-attach the protective tube to the cable breakout and then re-install tubing as described in [Step 5](#) and [Step 6](#).
11. Use lacing or cable ties to secure the protective tube or fiber subunit to the splice tray and verify that the distribution cable protective tube is the same length as the attached distribution row fiber tubes. Adjust as needed to make the lengths equal.



**Caution:** *Improper handling can damage fiber optic cables. Do not over tighten cable ties or lacing as this can cause damage or attenuation. Do not compress the fibers or allow them to kink.*

12. From the tie point on the splice tray, trim the **distribution cable fibers** to a cut length of 42 inches (107 cm) and the **distribution row fibers** to a cut length of 36 inches (91 cm).
  - ▶ **Note:** The ends of distribution pigtailed have been ribbonized at the factory for ease of splicing to ribbon cables. If splicing to stranded cable cut the ribbon ends off.
13. Splice the distribution cable fibers to the appropriate distribution pigtailed as specified by local policies and procedures. Adjust and route the fibers within the splice tray as shown in [Figure 16](#) or [Figure 17](#). Refer to [Table 5](#) for the distribution pigtail color code.

**Table 5. Distribution Pigtail Fiber Designations**

FIBER	COLOR
1	Blue
2	Orange
3	Green
4	Brown
5	Slate
6	White
7	Red
8	Black
9	Yellow
10	Violet
11	Rose
12	Aqua

14. After splicing is completed, re-install the clear plastic cover on the splice tray.

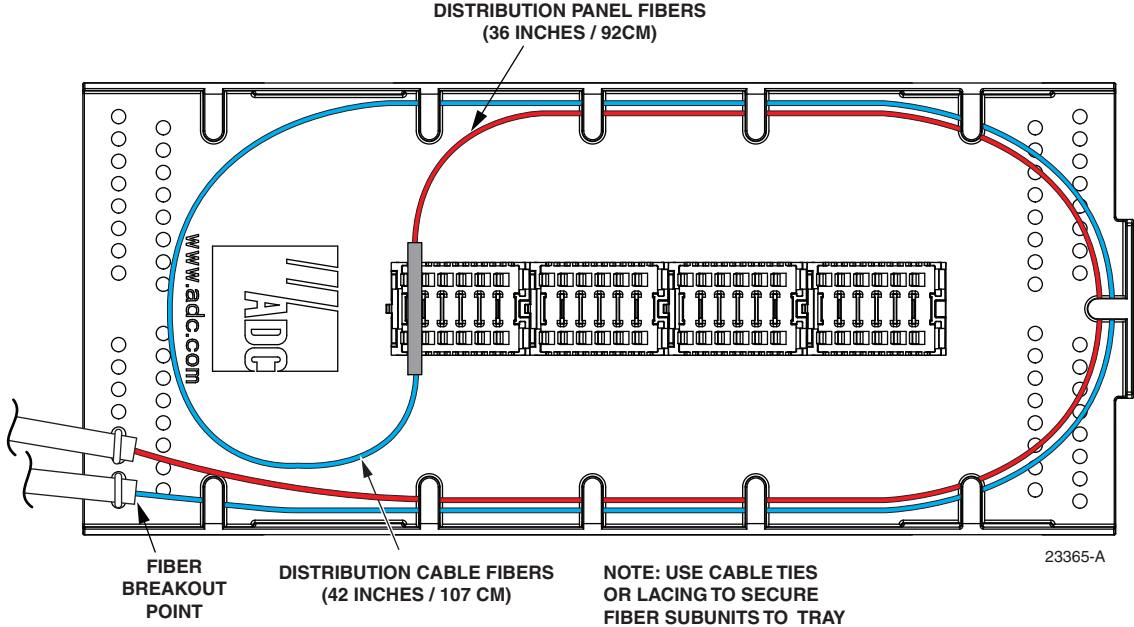

Figure 16. Ribbon Fiber Splice Tray - Distribution Cable Splicing

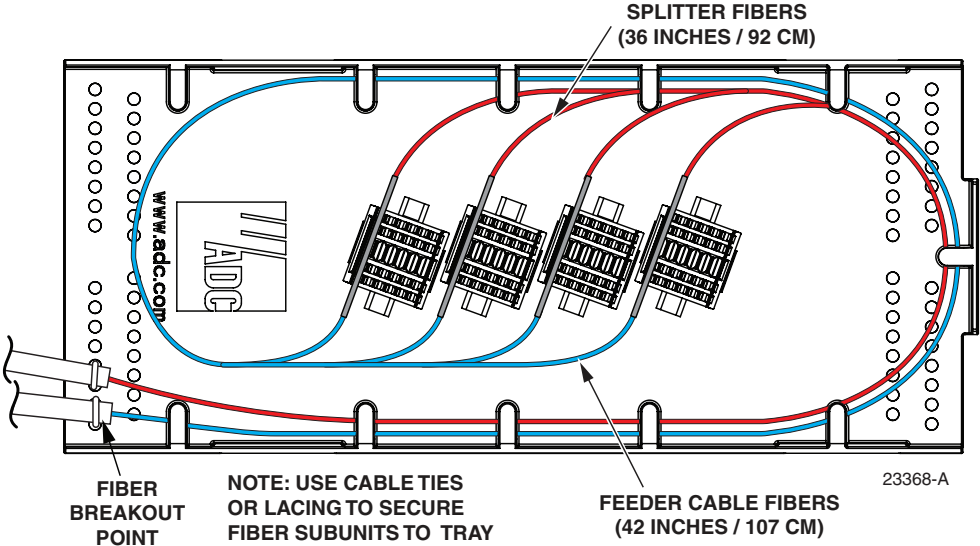
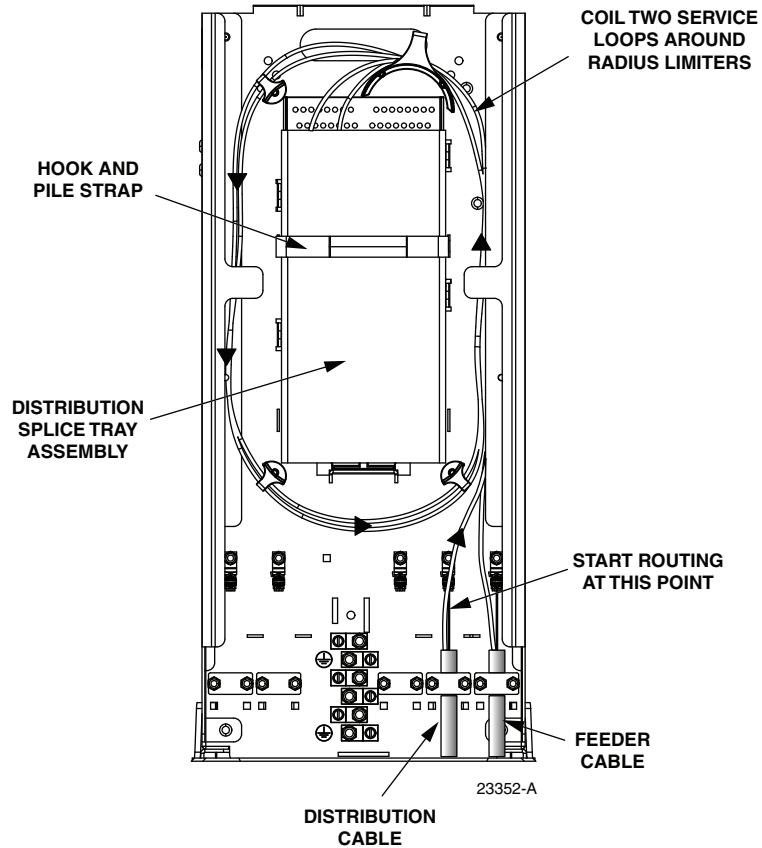

Figure 17. Stranded Fiber Splice Tray - Distribution Cable splicing (Four shown for clarity.)

15. To reinstall the splice tray, route the attached tubes around the distribution splice tray assembly as shown in Figure 18. Avoid twisting or kinking the fiber tubes.
16. Secure the splice tray to the splice tray assembly using the hook and pile strips.
17. Repeat Step 3 through Step 16 for each group of distribution rows.



**Figure 18. Distribution Splice Tray Installation**

## 6 PLUG AND PLAY SPLITTER MODULE INSTALLATION

The Hub in Pedestal FDH can accommodate up to six splitter modules. Plug and play splitter modules are equipped with either one or two input connectors. Inserting the splitter into the splitter compartment connects the splitter input connector(s) to the feeder cable connector(s). Each plug and play splitter module is also equipped with up to 64 connectorized output fibers. The splitter output fibers may be stored for later use or routed to the distribution rows for connection to the distribution ports. Additional instructions for installing plug and play splitter modules are provided in the FDH 3000 Plug and Play Splitter Installation Guide (ADCP-96-087). Use only splitters equipped with bend-optimized fibers.

Use the following procedure to install additional splitters in the pedestal:

1. Locate the next available splitter mounting position as shown in [Figure 19](#).

► **Note:** Install splitters in the order shown, beginning on the right side of the splitter compartment and then working toward the left.

2. Remove the dust cap assembly from the selected splitter slot.

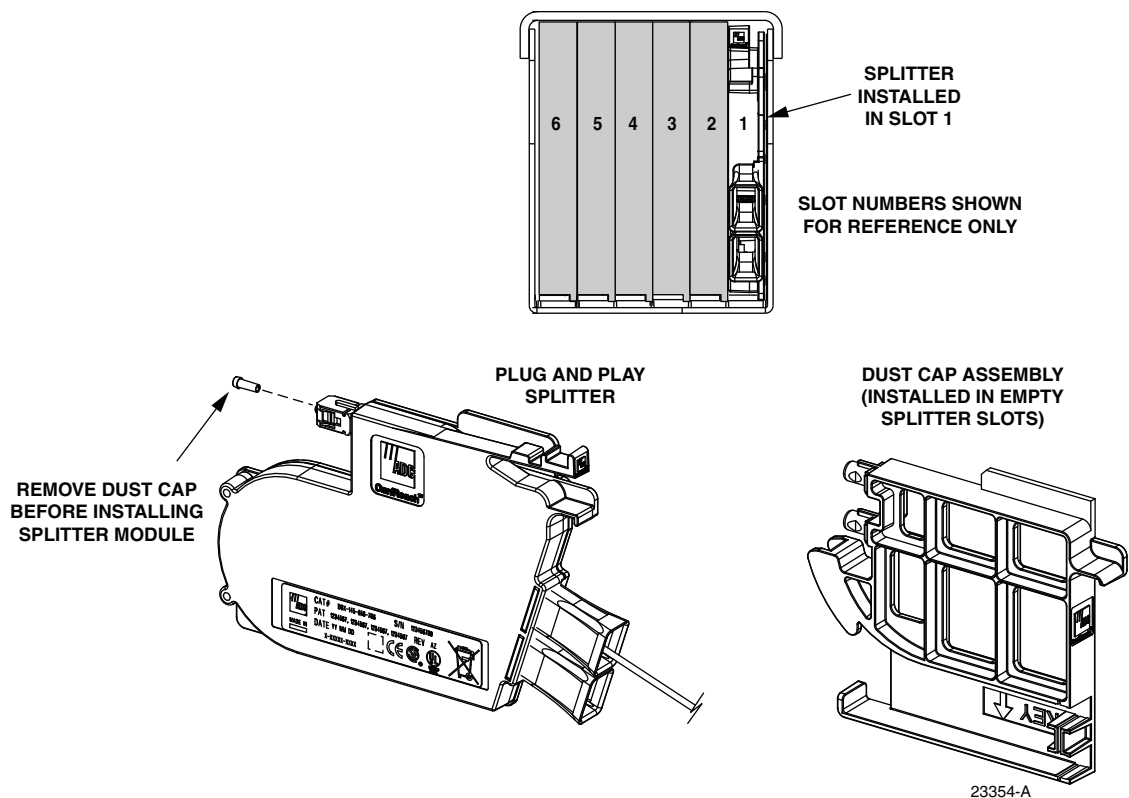
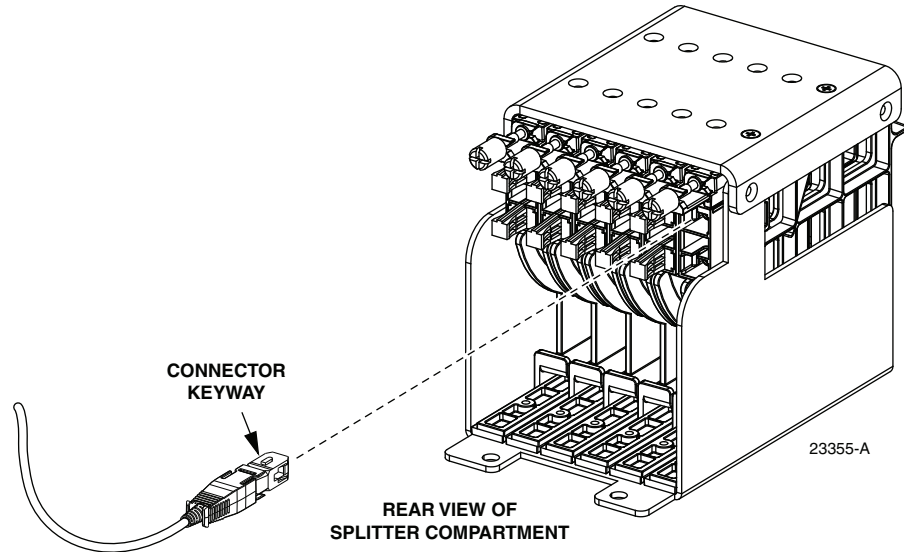

Figure 19. Splitter Module Installation

3. Remove the corresponding feeder cable connector(s) from the rear of the splitter compartment as shown in [Figure 20](#).



**Warning:** *Infrared radiation is invisible and can seriously damage the retina of the eye. Do not look into the ends of any optical fiber. Do not look directly into the optical adapters or connectors. Exposure to invisible laser radiation may result. An optical power meter should be used to verify active fibers. A protective cap or hood **MUST** be immediately placed over any radiating adapter or optical connector to avoid the potential of dangerous amounts of radiation exposure. This practice also prevents dirt particles from entering the adapter or connector.*



**Figure 20. Feeder Cable Connector**

4. Clean the feeder cable connector(s) as specified in the Optical Fiber Systems Cleaning and Mating Instructions (ADCP-90-159).
5. Reinstall the feeder cable connector(s) at the rear of the splitter compartment.
6. Remove protective tape and dust cap from splitter connectors and clean all connectors.

7. Grasp splitter and squeeze locking tab against lower tab with thumb and forefinger. Slide splitter into mounting slot until you hear the adapter click into the splitter compartment. See [Figure 21](#).



**Caution:** Do not force splitter into the mounting slot. Excessive force can cause splitter damage.

8. Route the splitter output fibers to the connector storage panel or to the designated subscriber port. Refer to [Section 7](#) for the routing procedure.

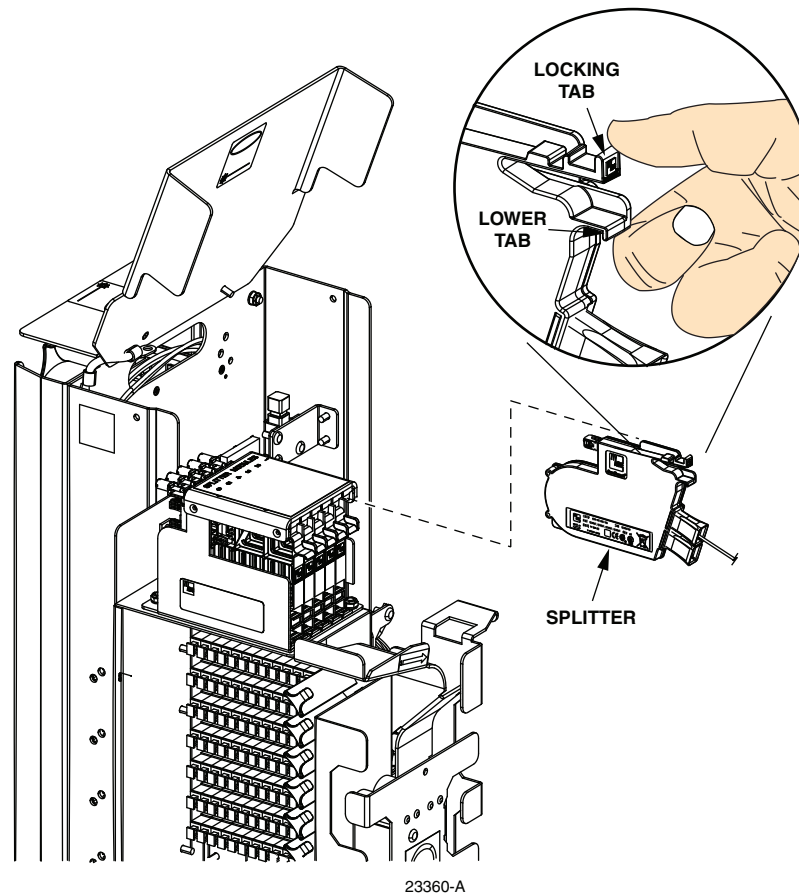

**Figure 21. Splitter Installation**

## 7 ROUTING AND CONNECTING THE SPLITTER OUTPUT FIBERS

The splitter modules are mounted at the top of the pedestal. When a splitter module is initially installed, the output fibers are routed to the storage panel located at the bottom of the pedestal. At the storage panel, the output fibers are temporarily “parked” until they are needed. Service to a subscriber is enabled by removing an unused output fiber from the storage panel, routing it to the appropriate distribution panel, and then connecting it to the subscriber port.

## 7.1 Storing The Splitter Output Fibers

Use the following procedure to store the splitter output fibers.

1. Following installation of a splitter module, route splitter output fibers through routing path following the arrows on the swing frame. Refer to [Figure 22](#) for additional routing guidelines.
2. Locate an open connector pack slot in the storage panel at the bottom of the pedestal, insert the connector pack into the unused slot in the storage panel. Refer to the FDH 3000 Plug and Play Splitter Installation Guide (ADCP-96-087) provided with splitter modules for additional information on installing connector packs in the storage panel.
3. Use the radius limiters in the pedestal to store any excess fiber slack.

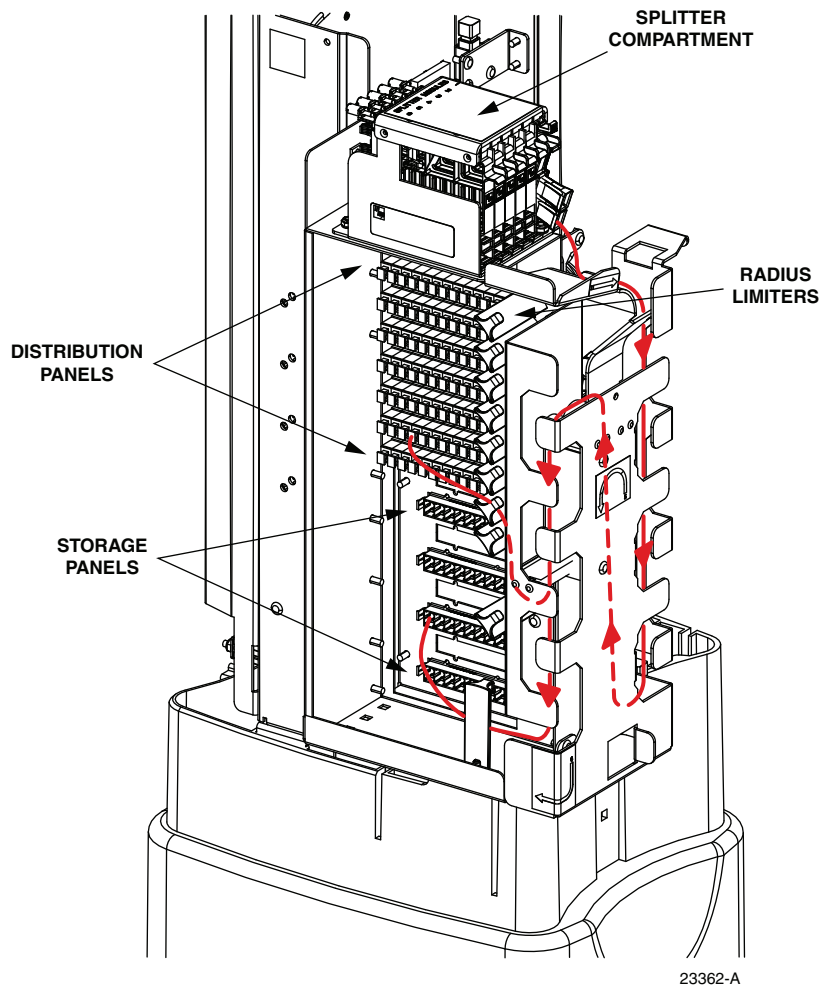

Figure 22. Routing Splitter Output Fibers



## 7.2 Enabling Service To a Subscriber

Use the following procedure to enable service to a subscriber:

1. Check the designation labels on the top to determine the distribution row and port number that corresponds to the address of the subscriber.
2. Locate the subscriber port on the specified distribution panel and remove adapter dust cap.



**Warning:** *Infrared radiation is invisible and can seriously damage the retina of the eye. Do not look into the ends of any optical fiber. Do not look directly into the optical adapters or connectors. Exposure to invisible laser radiation may result. An optical power meter should be used to verify active fibers. A protective cap or hood **MUST** be immediately placed over any radiating adapter or optical connector to avoid the potential of dangerous amounts of radiation exposure. This practice also prevents dirt particles from entering the adapter or connector.*

3. Select and remove an unused splitter output fiber from the storage panel and carefully work it free of any other fibers.
4. Remove the ferrule dust cap from the connector and then clean the connector as specified in the Optical Fiber Systems Cleaning and Mating Instructions (ADCP-90-159).
5. Connect the splitter output fiber connector to the subscriber port.
6. Use the radius limiters in the pedestal to store any excess fiber slack. Refer to [Figure 22](#) for the routing guidelines.



**Caution:** *Always allow sufficient fiber length to permit routing without severe bends. Non bend-optimized fibers may be permanently damaged if bent/curved to a radius of less than 1.5 in. (3.81 cm).*

## 8 SPLITTER COMPARTMENT PASS-THROUGH ROUTING PROCEDURE

Use the following procedure to bypass the splitter and route a jumper patch cord between a feeder cable and one of the distribution panel subscriber ports.

1. Open the cover and locate an open splitter mounting position.
2. Remove the dust cap assembly from the selected splitter slot.
3. Remove the feeder cable connector(s) from the rear of the splitter compartment (see [Figure 20](#)).



**Warning:** *Infrared radiation is invisible and can seriously damage the retina of the eye. Do not look into the ends of any optical fiber. Do not look directly into the optical adapters or connectors. Exposure to invisible laser radiation may result. An optical power meter should be used to verify active fibers. A protective cap or hood **MUST** be immediately placed over any radiating adapter or optical connector to avoid the potential of dangerous amounts of radiation exposure. This practice also prevents dirt particles from entering the adapter or connector.*

4. Clean the feeder cable connector(s) as specified in the Optical Fiber Systems Cleaning and Mating Instructions (ADCP-90-159).

5. Reinstall the feeder cable connector(s) at the rear of the splitter compartment.
  6. Obtain the optical patch cord (accessory) recommended for the pass-through connection.
  7. Remove the ferrule dust cap from one of the patch cord connectors and then clean the connector as specified in the Optical Fiber Connector Wet and Dry Cleaning Instructions (ADCP-90-159) or by locally approved procedures.
  8. Install the patch cord connector in the dust cap assembly as shown in [Figure 23](#).
- **Note:** Two patch cord connectors may be installed in the dust cap assembly if required.

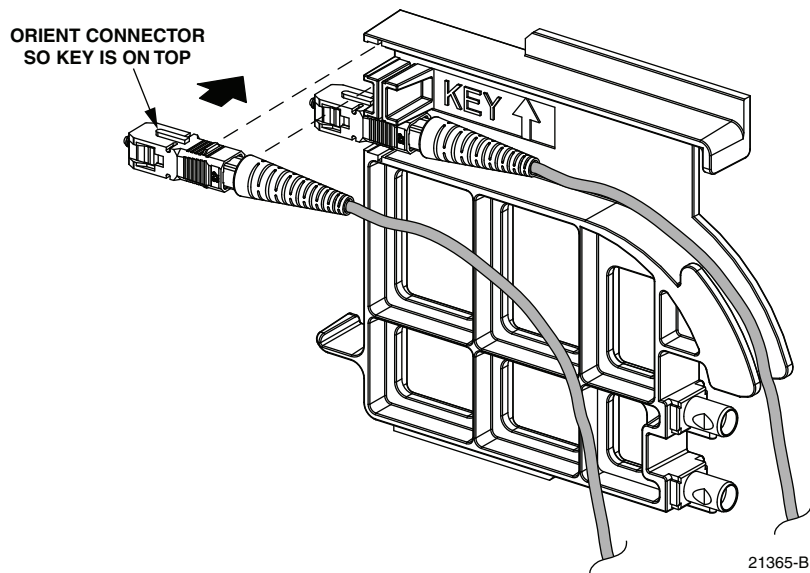

**Figure 23. Installing Patch Cord Connector in Dust Cap Assembly**

9. Connect the patch cord connector(s) to the feeder cable connector(s) by inserting the dust cap assembly into the splitter slot as shown in [Figure 24](#).
10. Route patch cords through routing path following the arrows on the swing frame.
11. Locate the distribution panel and the optical port to which the pass-through patch cord is to be routed.
12. Refer to the procedures in [Section 7.2](#) to route the pass-through patch cord to the distribution panel and to connect the patch cord connector to the appropriate optical port.
13. Close splitter cover when pass-through routing procedure is complete.

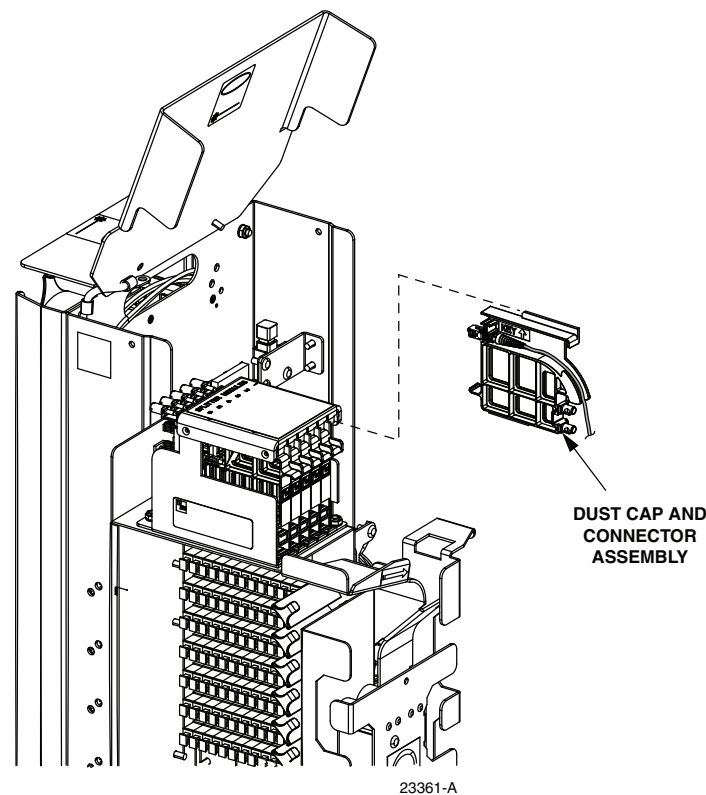

Figure 24. Inserting Dust Cap Assembly Into Splitter Compartment

## 9 ADDING DISTRIBUTION CAPACITY TO AN EXISTING PEDESTAL

The Hub in Pedestal was most likely ordered with the minimum number of terminations required for the location at the time of installation. As the area develops additional terminations may be added to the Hub in Pedestal. A 12-termination growth kit FD3-PACCF2GRW is available to add 12 new fibers at a time.

Check distribution fiber splice trays to see if there is room to add 12 additional splices. Each splice tray has room for 24-splices, if only 12-splices are in a tray you can add 12 more. If all distribution splice trays contain 24-splices you will need to add another splice tray.

1. Locate an empty adapter row in the adapter bulkhead.

► **Note:** Always clean and inspect connectors and adapters before mating them. For guidelines, refer to ADCP-90-159.

2. Install 12-SC adapters in the adapter row.
3. Secure cable fanout at fanout mounting location using cable ties.
4. Connect terminated fibers from cable to the SC adapters.

5. Route fiber cable to the distribution splice tray area. Route distribution fibers through the opening in the top of the HUB frame through the retaining clips to the adapters in the swing frame, see [Figure 25](#).
6. Remove tray if splicing in an existing splice tray.
7. If an additional splice tray is required, obtain the splice tray.
8. Splice fiber cables to distribution cables.
9. Replace splice tray securing it to the splice tray assembly using the hook and pile strips.

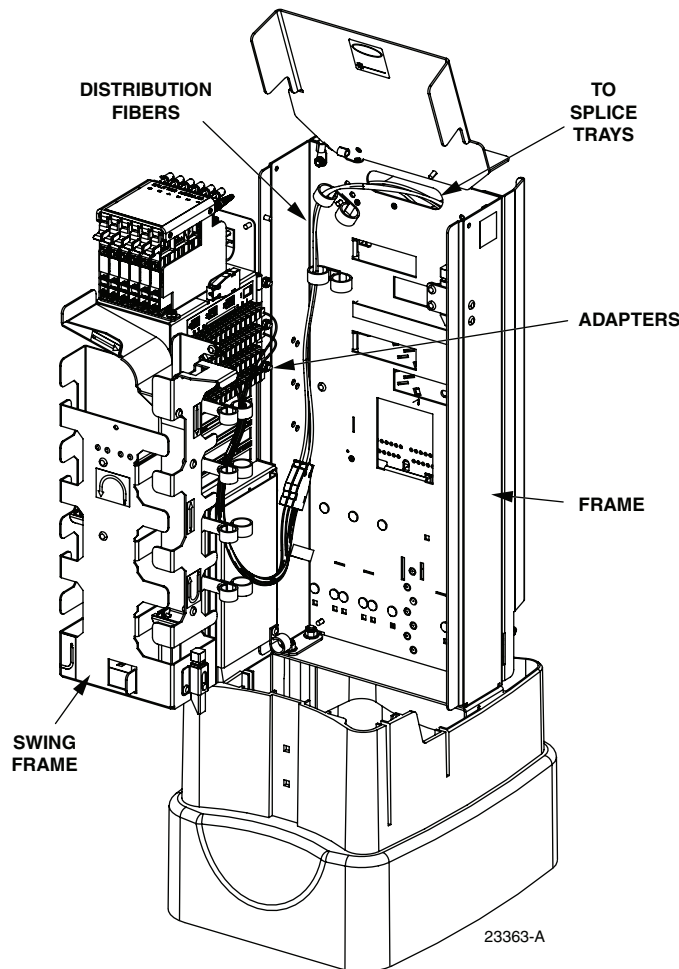

**Figure 25. Distribution Fiber Routing**

## 10 INSTALL LOCAL CUSTOMER DROPS

Up to four customers may be served from the pedestal by adding hardened drop kits. Two kits are available:

- FD3-PACCDRPKT kit includes the hardened adapter mounting bracket, hardened adapter, SC adapter, and fiber cable to serve the first customer.

- FD3-PACCDPGRW kit includes hardened adapter, SC adapter, and fiber cable to serve an additional customer.
1. Place hardened adapter mounting bracket over the mounting stud in the swing frame at the back of the pedestal with the extensions inserted into the slots in the swing frame. See [Figure 26](#).

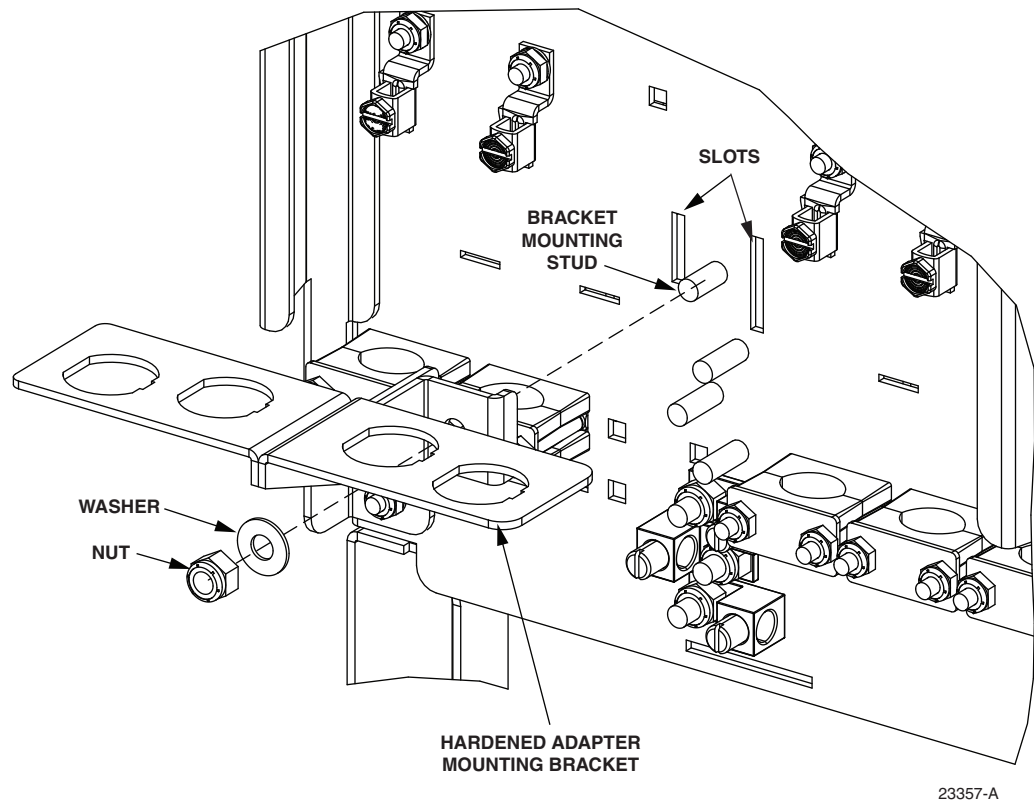

**Figure 26. Adapter Mounting Bracket Installation**

2. Secure adapter mounting bracket to pedestal frame with washer and nut provided.
  3. Remove retaining nut from hardened adapter ([Figure 27](#)). Slide hardened adapter into the mounting bracket from the bottom.
  4. Install hardened adapter retaining nut and hand tighten.
  5. Install SC adapter in one of the four available drop port locations at the top of the adapter bulkhead.
- **Note:** Always clean and inspect connectors and adapters before mating them. For guidelines, refer to ADCP-90-159.
6. Connect patchcord to SC adapter in bulkhead.
  7. Starting at the bulkhead adapter route the patchcord through the swing frame and around the splice trays. Place this patchcord in the extra set of clips located along the left side of the pedestal. Loop the patchcord around the splice trays to take up any extra slack.

8. Refer to your work order to determine which splitter output to connect to the other side of the SC adapter.
9. Remove the splitter output from the parking lot and route it to the SC adapter. Connect splitter output to the SC adapter.

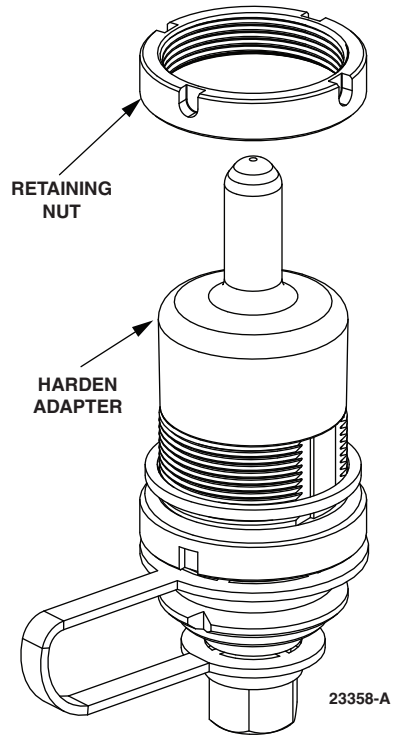

**Figure 27. Preparing hardened Adapter**

10. Connect customer drop cable (OptiTap®) to the bottom of the hardened adapter.
11. Repeat [Step 3](#) through [Step 10](#) for each customer drop.

## 11 MAINTENANCE AND REPAIR PROCEDURES

The Hub in Pedestal FDH requires no regular maintenance to insure continuous and satisfactory operation. Maintenance is limited to repairing or replacing any pedestal components that may be damaged or broken in the course of normal operation. The following sections provide procedures for repairing or replacing common pedestal components.

### 11.1 Distribution Row Adapter Replacement

Replacement adapters are available for the distribution rows. Use the following procedure to remove and replace a damaged adapter:

1. Disconnect the splitter connector from the front side of the broken adapter as shown in [Figure 28](#) and install a dust cap on the connector.



**Warning:** *Infrared radiation is invisible and can seriously damage the retina of the eye. Do not look into the ends of any optical fiber. Do not look directly into the optical adapters or connectors. Exposure to invisible laser radiation may result. An optical power meter should be used to verify active fibers. A protective cap or hood **MUST** be immediately placed over any radiating adapter or optical connector to avoid the potential of dangerous amounts of radiation exposure. This practice also prevents dirt particles from entering the adapter or connector.*

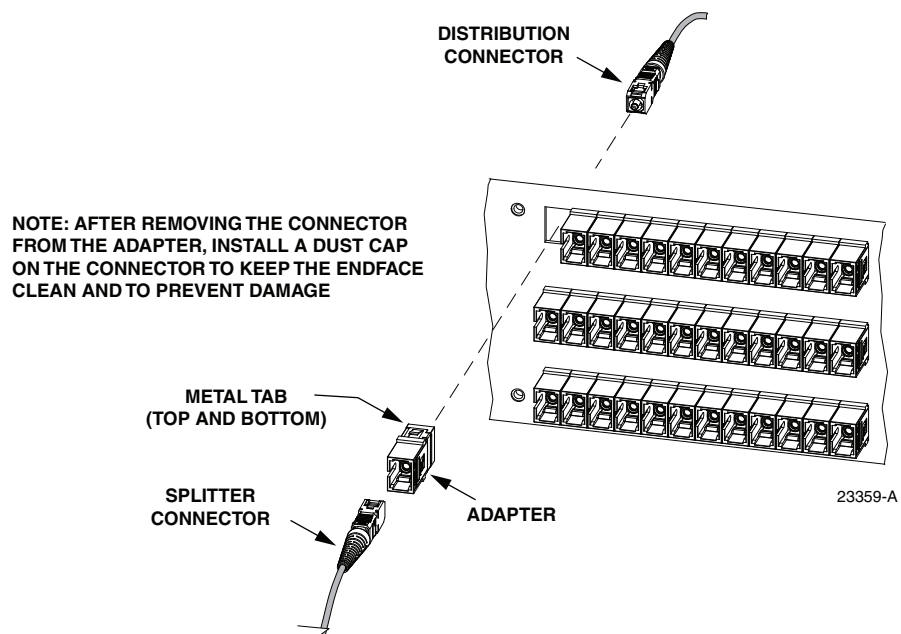

**Figure 28. Adapter Removal and Replacement - Typical Distribution Panel**

2. Unlatch and fully open the pedestal swing frame to provide access to the rear side of the distribution panel.
3. Disconnect the distribution connector from the rear side of the broken adapter and install a dust cap on the connector.



**Caution:** *Use extreme care when removing a connector or an adapter from the distribution panel to avoid macro bending the adjacent fibers.*

4. Working from the rear side of the distribution panel, depress the two metal tabs that retain the adapter in the panel. Then push forward on the adapter until it pops out of the panel.
  5. Discard the damaged adapter.
  6. Install the replacement adapter by inserting it into the distribution panel from the front and then pushing it toward the back until it snaps into place.
- ▶ **Note:** Make sure the keyway in the replacement adapter is facing in the same direction as the keyways in the rest of the adapters installed in the distribution panel.
7. Clean the distribution and splitter fiber connectors as specified in the Optical Fiber Systems Cleaning and Mating Instructions (ADCP-90-159).
  8. Connect the distribution connector to the rear side of the replacement adapter.
  9. Close the pedestal swing frame.
  10. Connect the splitter connector to the front side of the replacement adapter.

## 11.2 Splitter Compartment Adapter Replacement

Replacement adapter assemblies are available for the splitter compartment. Use the following procedure to remove and replace a damaged adapter assembly:

1. Open splitter cover to gain access to the splitter compartment.
2. Remove the splitter or the dust cap assembly from the front side of the broken adapter assembly.



**Warning:** *Infrared radiation is invisible and can seriously damage the retina of the eye. Do not look into the ends of any optical fiber. Do not look directly into the optical adapters or connectors. Exposure to invisible laser radiation may result. An optical power meter should be used to verify active fibers. A protective cap or hood **MUST** be immediately placed over any radiating adapter or optical connector to avoid the potential of dangerous amounts of radiation exposure. This practice also prevents dirt particles from entering the adapter or connector.*

3. Remove the feeder cable connector(s) from the rear side of the broken adapter assembly as shown in [Figure 29](#) and install a dust cap on the connector(s).
4. Turn the thumb screw on the top of the broken adapter assembly clockwise until the adapter assembly detaches from the top of the splitter compartment.
5. Discard the damaged adapter assembly.



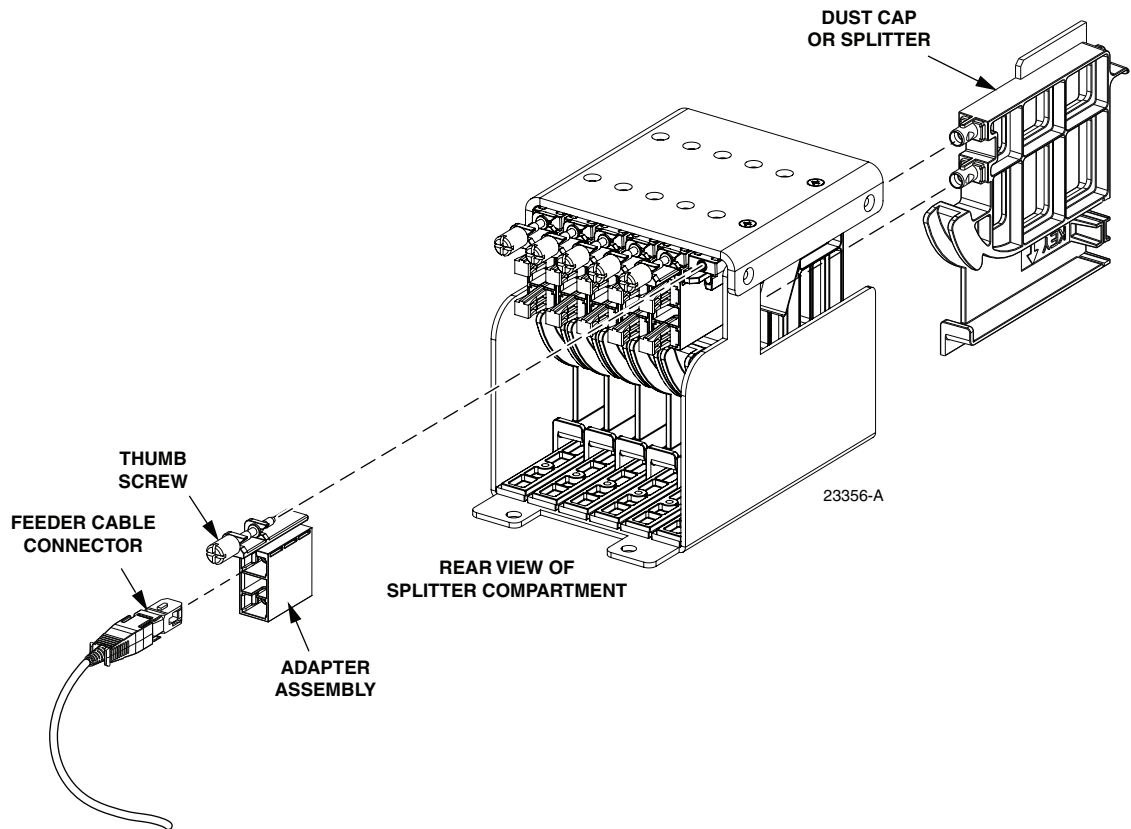

**Figure 29. Splitter Compartment Adapter Replacement**

6. Install the replacement adapter assembly in the splitter compartment and secure it by turning the thumbscrew counter-clockwise until tight.
7. Clean the feeder cable connector(s) as specified in the Optical Fiber Systems Cleaning and Mating Instructions (ADCP-90-159).
8. Connect the feeder cable connector to the rear side of the replacement adapter assembly.
9. Connect the dust cap or splitter to the front side of the replacement adapter assembly.
10. Close the pedestal swing frame.

### 11.3 Replacing a Damaged Fiber or Connector

A damaged fiber or connector can usually be replaced. The following describes the various replacement options.

- **Damaged Splitter Output Fiber:** Replace the splitter output fiber from the connector all the way back into the splitter. Splice a new pigtail (use only pigtails with bend-optimized fiber) to the remaining section of the old fiber within the splitter chassis. This procedure requires removing and disassembling the splitter to insert a splice chip and to perform the splice. A kit is available from ADC. Refer to ADCP-96-034 for the procedure.

- **Damaged Distribution or Feeder Connector:** Replace the connector at the bulkhead adapter if just the connector alone is damaged. Use a field-installable connector replacement kit. Refer to [Section 11.3.1](#) for the replacement procedures.

### 11.3.1 Splitter Output Fiber Connector Replacement

Use the following procedure to replace the connector:

1. Disconnect the damaged connector and the good connector from the adapter and install a dust cap on the good connector.



**Warning:** *Infrared radiation is invisible and can seriously damage the retina of the eye. Do not look into the ends of any optical fiber. Do not look directly into the optical adapters or connectors. Exposure to invisible laser radiation may result. An optical power meter should be used to verify active fibers. A protective cap or hood MUST be immediately placed over any radiating adapter or optical connector to avoid the potential of dangerous amounts of radiation exposure. This practice also prevents dirt particles from entering the adapter or connector.*

2. Replace the damaged connector as specified in the procedures provided with the field-installable connector replacement kit.
3. Clean both connectors as specified in the Optical Fiber Connector Wet and Dry Cleaning Instructions (ADCP-90-159) or by locally approved procedures.
4. Reconnect the good connector and the replacement connector to the adapter.

## 12 GROUNDING SYSTEM TERMINAL ACCESS PROCEDURE

Fiber optic cables with metallic strength members or shields are grounded to a common grounding system. The grounding system is designed to allow the metallic elements of each cable to be isolated for connection of cable locating equipment. The grounding system terminals may be accessed by removing the pedestal cover. Use the following procedure to access and isolate the metallic elements of individual cables:

1. Use the 216B tool to remove the screw that secures the pedestal cover to the base.
2. Remove pedestal cover and locate the grounding stud that corresponds to the cable to be located.

► **Note:** A designation label is provided on the top of the pedestal frame for identifying cables.

3. Loosen the screw in the ground lug and disconnect the cable so that it is not touching the ground lug area, see [Figure 30](#).
4. Attach cable detection equipment to the isolated grounding cable and complete the cable location procedure.
5. When finished locating cables, reconnect the cable to the grounding lug.
6. Tighten the grounding stud nut to 30 to 35 lbs force-inches. (3.4 to 4.0 Nm) of torque.



**Warning:** *The grounding cables are connected to pedestal ground through the copper ground lugs. Failure to properly tighten the nut on each individual cable grounding stud could result in improper grounding of the cable and result in performance or safety issues.*

7. Replace pedestal cover and secure in place.

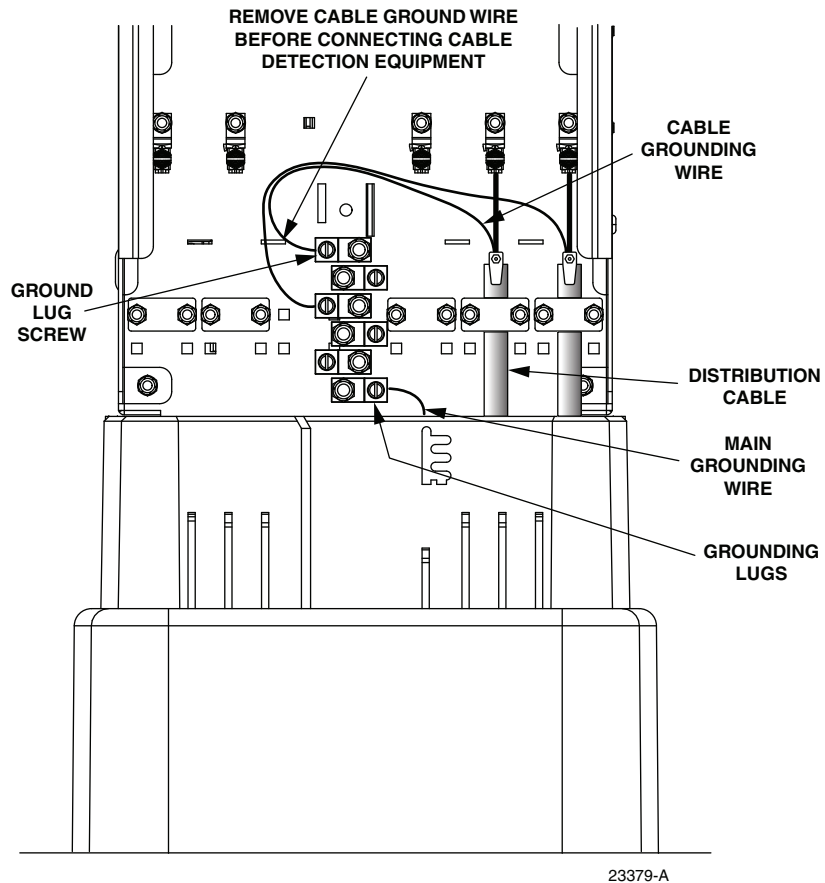

**Figure 30. Grounding Block Access**

## 13 CUSTOMER INFORMATION AND ASSISTANCE



### PHONE:

#### U.S.A. or CANADA

Sales: .....1-800-366-3891  
 Extension .....73000  
 Technical Assistance: .....1-800-366-3891  
 Connectivity Extension: .....73475  
 Wireless Extension: .....73476

#### EUROPE

Sales Administration: .....+32-2-712-65 00  
 Technical Assistance: .....+32-2-712-65 42

#### EUROPEAN TOLL FREE NUMBERS

Germany: .....0180 2232923  
 UK: .....0800 960236  
 Spain: .....900 983291  
 France: .....0800 914032  
 Italy: .....0800 782374

#### ASIA/PACIFIC

Sales Administration: .....+65-6294-9948  
 Technical Assistance: .....+65-6393-0739

#### ELSEWHERE

Sales Administration: .....+1-952-917-3000  
 Technical Assistance: .....+1-952-917-3475

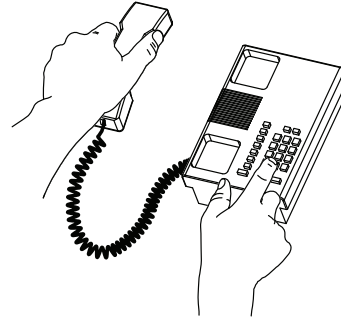

13944-Q

### WRITE:

**ADC Telecommunications (S'PORE) PTE, LTD;**  
**100 Beach Road, #18-01, Shaw Towers.**  
**Singapore 189702.**

**ADC Telecommunications, INC**  
**PO Box 1101,**  
**Minneapolis, MN 55440-1101, USA**

**ADC European Customer Service, INC**  
**Belgicastraat 2,**  
**1930 Zaventem, Belgium**

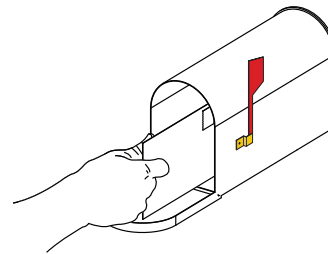

### PRODUCT INFORMATION AND TECHNICAL ASSISTANCE:

[connectivity.tac@adc.com](mailto:connectivity.tac@adc.com)  
[wireless.tac@adc.com](mailto:wireless.tac@adc.com)  
[euro.tac@adc.com](mailto:euro.tac@adc.com)  
[asiapacific.tac@adc.com](mailto:asiapacific.tac@adc.com)

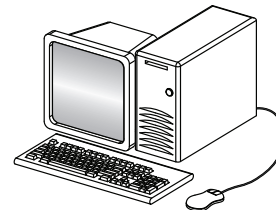

### REPRINTS:

PDF copies of manuals are available  
 for downloading at the following link:

[www.adc.com/manuals](http://www.adc.com/manuals)

ADCP Number: **96-155**

Contents herein are current as of the date of publication. ADC reserves the right to change the contents without prior notice. **In no event shall ADC be liable for any damages resulting from loss of data, loss of use, or loss of profits and ADC further disclaims any and all liability for indirect, incidental, special, consequential or other similar damages. This disclaimer of liability applies to all products, publications and services during and after the warranty period.**