

# C400D-DMDM-1M-X

---

CNT-400-DB CNT® Jumper with interface types 7-16 DIN Male and 7-16 DIN Male, 1 m



## Product Classification

<b>Product Type</b>	Braided cable assembly
<b>Product Brand</b>	CNT®
<b>Product Series</b>	CNT-400

## General Specifications

<b>Attachment, Connector B</b>	Field attachment
<b>Body Style, Connector A</b>	Straight
<b>Body Style, Connector B</b>	Straight
<b>Cable Family</b>	CNT-400
<b>Interface, Connector A</b>	7-16 DIN Male
<b>Interface, Connector B</b>	7-16 DIN Male
<b>Specification Sheet Revision Level</b>	A

## Dimensions

<b>Length</b>	1 m   3.281 ft
<b>Nominal Size</b>	0.400 in

## Electrical Specifications

<b>DTF, Connector A</b>	-28 dB
<b>DTF, Connector B</b>	-28 dB

## Jumper Assembly Sample Label

# C400D-DMDM-1M-X



## Regulatory Compliance/Certifications

### Agency

ISO 9001:2015



### Classification

Designed, manufactured and/or distributed under this quality management system

## Included Products

- 400BPDM-C – 7-16 DIN Male for CNT-400 braided cable
- 400BPDM-CR – 7-16 DIN Male for CNT-400 and CNT-400-Flex braided cable
- 400PDM-C – 7-16 DIN Male for CNT-400 braided cable
- CNT-400-DB – CNT-400-DB, CNT® 50 Ohm Braided Coaxial Cable, flooded, black PE jacket

# 400BPDM-C

---



7-16 DIN Male for CNT-400 braided cable

## Product Classification

<b>Product Type</b>	Braided cable connector
<b>Product Brand</b>	CNT®

## General Specifications

<b>Body Style</b>	Straight
<b>Inner Contact Attachment Method</b>	Captivated
<b>Inner Contact Plating</b>	Silver
<b>Interface</b>	7-16 DIN Male
<b>Outer Contact Attachment Method</b>	Clamp
<b>Outer Contact Plating</b>	Trimetal

## Dimensions

<b>Width</b>	35 mm   1.378 in
<b>Length</b>	40.73 mm   1.604 in
<b>Diameter</b>	35 mm   1.378 in
<b>Nominal Size</b>	0.405 in

## Outline Drawing

# 400BPDM-C

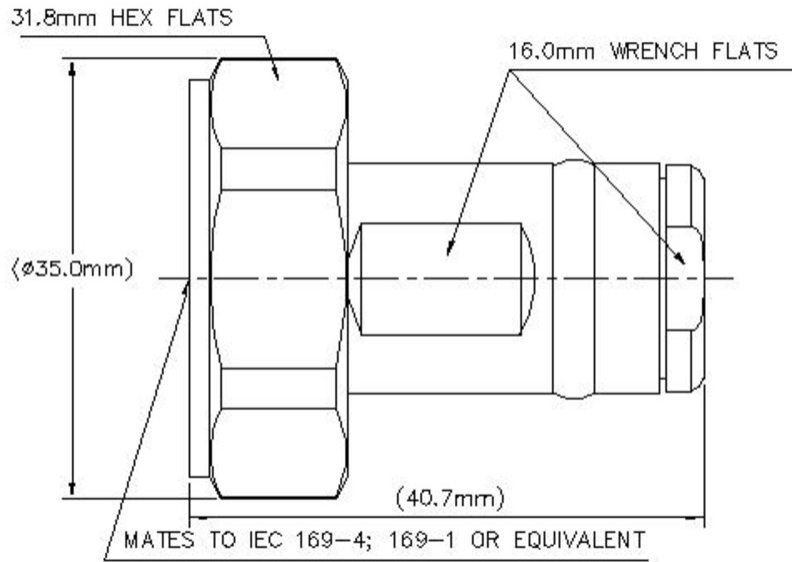

## Electrical Specifications

<b>Insertion Loss, typical</b>	0.05 dB
<b>Average Power at Frequency</b>	580.0 W @ 900 MHz
<b>Cable Impedance</b>	50 ohm
<b>Connector Impedance</b>	50 ohm
<b>dc Test Voltage</b>	2500 V
<b>Inner Contact Resistance, maximum</b>	1.5 mOhm
<b>Insulation Resistance, minimum</b>	10000 MOhm
<b>Operating Frequency Band</b>	0 – 6000 MHz
<b>Outer Contact Resistance, maximum</b>	0.4 mOhm
<b>RF Operating Voltage, maximum (vrms)</b>	894 V

## VSWR/Return Loss

Frequency Band	VSWR	Return Loss (dB)
0–3000 MHz	1.05	32.26
3000–6000 MHz	1.12	25

## Mechanical Specifications

<b>Connector Retention Tensile Force</b>	330 N   74.187 lbf
<b>Connector Retention Torque</b>	0.56 N-m   4.956 in lb

# 400BPDM-C

---

<b>Coupling Nut Proof Torque</b>	35 N-m   309.776 in lb
<b>Coupling Nut Proof Torque Method</b>	IEC 61169-4:9.3.6
<b>Coupling Nut Retention Force</b>	1000 N   224.809 lbf
<b>Coupling Nut Retention Force Method</b>	IEC 61169-4:15.2.6
<b>Interface Durability</b>	500 cycles
<b>Interface Durability Method</b>	IEC 61169-4:17
<b>Mechanical Shock Test Method</b>	IEC 60068-2-27

## Environmental Specifications

<b>Operating Temperature</b>	-40 °C to +85 °C (-40 °F to +185 °F)
<b>Storage Temperature</b>	-65 °C to +125 °C (-85 °F to +257 °F)
<b>Attenuation, Ambient Temperature</b>	20 °C   68 °F
<b>Average Power, Ambient Temperature</b>	40 °C   104 °F
<b>Average Power, Inner Conductor Temperature</b>	100 °C   212 °F
<b>Climatic Sequence Test Method</b>	IEC 60068-1
<b>Corrosion Test Method</b>	IEC 60068-2-11
<b>Damp Heat Steady State Test Method</b>	IEC 60068-2-3
<b>Immersion Depth</b>	1 m
<b>Immersion Test Mating</b>	Mated
<b>Immersion Test Method</b>	IEC 60529:2001, IP68
<b>Thermal Shock Test Method</b>	IEC 60068-2-14
<b>Vibration Test Method</b>	IEC 60068-2-6

## Packaging and Weights

<b>Weight, net</b>	44.58 g   0.098 lb
--------------------	--------------------

## Regulatory Compliance/Certifications

<b>Agency</b>	<b>Classification</b>
CHINA-ROHS	Below maximum concentration value
ISO 9001:2015	Designed, manufactured and/or distributed under this quality management system
REACH-SVHC	Compliant as per SVHC revision on <a href="http://www.commscope.com/ProductCompliance">www.commscope.com/ProductCompliance</a>
ROHS	Compliant

# 400BPDM-C

---



## \* Footnotes

- Insertion Loss, typical** 0.05 dB/freq (GHz) (not applicable for elliptical waveguide)
- Immersion Depth** Immersion at specified depth for 24 hours

# 400BPDM-CR

---



7-16 DIN Male for CNT-400 and CNT-400-Flex braided cable

## Product Classification

<b>Product Type</b>	Braided cable connector
<b>Product Brand</b>	CNT®

## General Specifications

<b>Body Style</b>	Straight
<b>Inner Contact Attachment Method</b>	Solder
<b>Inner Contact Plating</b>	Silver
<b>Interface</b>	7-16 DIN Male
<b>Outer Contact Attachment Method</b>	Crimp
<b>Outer Contact Plating</b>	Trimetal

## Dimensions

<b>Width</b>	35 mm   1.378 in
<b>Length</b>	38.12 mm   1.501 in
<b>Diameter</b>	35 mm   1.378 in
<b>Nominal Size</b>	0.405 in

## Outline Drawing

# 400BPDM-CR

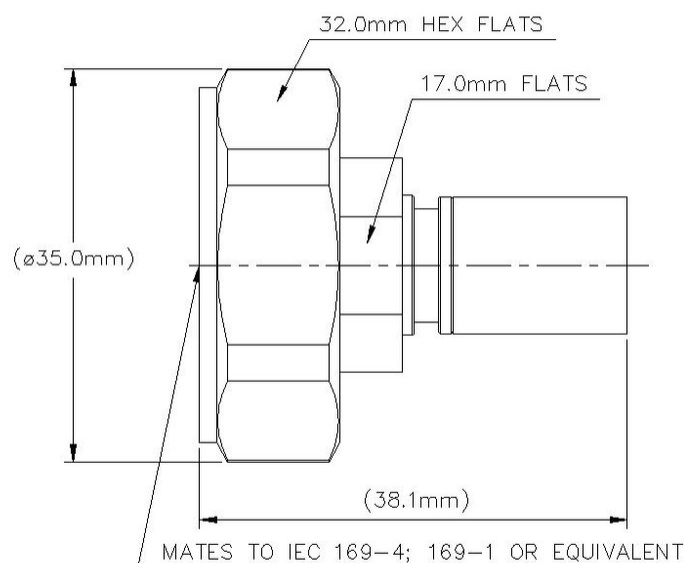

## Electrical Specifications

<b>Insertion Loss, typical</b>	0.05 dB
<b>Average Power at Frequency</b>	580.0 W @ 900 MHz
<b>Cable Impedance</b>	50 ohm
<b>Connector Impedance</b>	50 ohm
<b>dc Test Voltage</b>	2500 V
<b>Inner Contact Resistance, maximum</b>	1.5 mOhm
<b>Insulation Resistance, minimum</b>	10000 MOhm
<b>Operating Frequency Band</b>	0 – 6000 MHz
<b>Outer Contact Resistance, maximum</b>	0.4 mOhm
<b>RF Operating Voltage, maximum (vrms)</b>	894 V

## VSWR/Return Loss

Frequency Band	VSWR	Return Loss (dB)
0–3000 MHz	1.08	28.3
3000–6000 MHz	1.2	20.83



# 400BPDM-CR

---

## Mechanical Specifications

<b>Connector Retention Tensile Force</b>	330 N   74.187 lbf
<b>Connector Retention Torque</b>	0.56 N-m   4.956 in lb
<b>Coupling Nut Proof Torque</b>	35 N-m   309.776 in lb
<b>Coupling Nut Proof Torque Method</b>	IEC 61169-4:9.3.6
<b>Coupling Nut Retention Force</b>	1000 N   224.809 lbf
<b>Coupling Nut Retention Force Method</b>	IEC 61169-4:15.2.6
<b>Interface Durability</b>	500 cycles
<b>Interface Durability Method</b>	IEC 61169-4:17
<b>Mechanical Shock Test Method</b>	IEC 60068-2-27

## Environmental Specifications

<b>Operating Temperature</b>	-40 °C to +85 °C (-40 °F to +185 °F)
<b>Storage Temperature</b>	-65 °C to +125 °C (-85 °F to +257 °F)
<b>Attenuation, Ambient Temperature</b>	20 °C   68 °F
<b>Average Power, Ambient Temperature</b>	40 °C   104 °F
<b>Average Power, Inner Conductor Temperature</b>	100 °C   212 °F
<b>Climatic Sequence Test Method</b>	IEC 60068-1
<b>Corrosion Test Method</b>	IEC 60068-2-11
<b>Damp Heat Steady State Test Method</b>	IEC 60068-2-3
<b>Thermal Shock Test Method</b>	IEC 60068-2-14
<b>Vibration Test Method</b>	IEC 60068-2-6
<b>Water Jetting Test Mating</b>	Mated
<b>Water Jetting Test Method</b>	IEC 60529:2001, IP65

## Packaging and Weights

<b>Weight, net</b>	57.2 g   0.126 lb
--------------------	-------------------

## Regulatory Compliance/Certifications

<b>Agency</b>	<b>Classification</b>
ISO 9001:2015	Designed, manufactured and/or distributed under this quality management system



# 400BPDM-CR

---

## \* Footnotes

**Insertion Loss, typical** 0.05v<sup>-1</sup>freq (GHz) (not applicable for elliptical waveguide)

# 400PDM-C

---

7-16 DIN Male for CNT-400 braided cable

## Product Classification

<b>Product Type</b>	Braided cable connector
<b>Product Brand</b>	CNT®   ConQuest®

## General Specifications

<b>Body Style</b>	Straight
<b>Inner Contact Attachment Method</b>	Captivated
<b>Inner Contact Plating</b>	Silver
<b>Interface</b>	7-16 DIN Male
<b>Outer Contact Attachment Method</b>	Clamp
<b>Outer Contact Plating</b>	Trimetal
<b>Pressurizable</b>	No

## Dimensions

<b>Width</b>	34.6 mm   1.362 in
<b>Length</b>	42.41 mm   1.67 in
<b>Diameter</b>	34.6 mm   1.362 in
<b>Nominal Size</b>	0.405 in

## Outline Drawing

# 400PDM-C

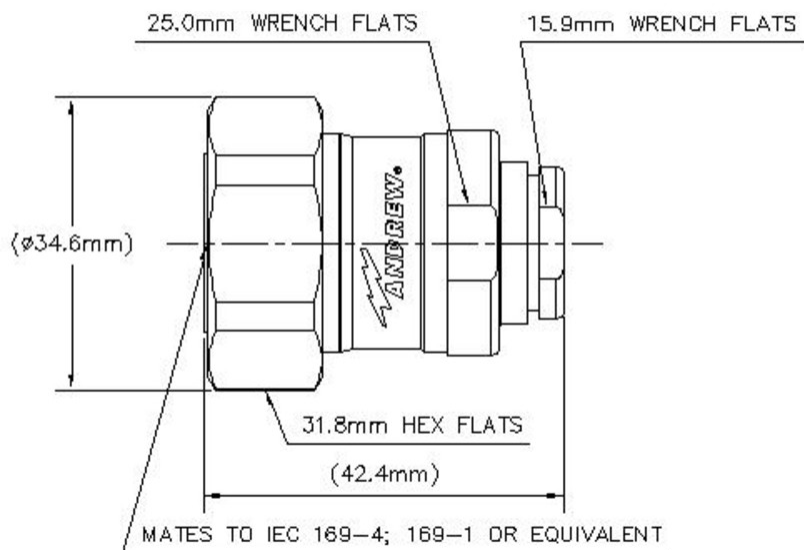

## Electrical Specifications

<b>Insertion Loss, typical</b>	0.05 dB
<b>Average Power at Frequency</b>	580.0 W @ 900 MHz
<b>Cable Impedance</b>	50 ohm
<b>Connector Impedance</b>	50 ohm
<b>dc Test Voltage</b>	2500 V
<b>Inner Contact Resistance, maximum</b>	0.4 mOhm
<b>Insulation Resistance, minimum</b>	10000 MOhm
<b>Operating Frequency Band</b>	0 – 6000 MHz
<b>Outer Contact Resistance, maximum</b>	1.5 mOhm
<b>Peak Power, maximum</b>	16 kW
<b>RF Operating Voltage, maximum (vrms)</b>	894 V

## VSWR/Return Loss

Frequency Band	VSWR	Return Loss (dB)
0–3000 MHz	1.06	31
3000–6000 MHz	1.12	25

## Mechanical Specifications

<b>Connector Retention Tensile Force</b>	330 N   74.187 lbf
--	--------------------

# 400PDM-C

---

<b>Connector Retention Torque</b>	0.56 N-m   4.956 in lb
<b>Coupling Nut Proof Torque</b>	50 N-m   442.537 in lb
<b>Coupling Nut Proof Torque Method</b>	IEC 61169-4:9.3.6
<b>Coupling Nut Retention Force</b>	800 N   179.847 lbf
<b>Coupling Nut Retention Force Method</b>	IEC 61169-4:15.2.6
<b>Interface Durability</b>	500 cycles
<b>Interface Durability Method</b>	IEC 61169-4:17
<b>Mechanical Shock Test Method</b>	IEC 60068-2-27

## Environmental Specifications

<b>Operating Temperature</b>	-40 °C to +85 °C (-40 °F to +185 °F)
<b>Storage Temperature</b>	-65 °C to +125 °C (-85 °F to +257 °F)
<b>Attenuation, Ambient Temperature</b>	20 °C   68 °F
<b>Average Power, Ambient Temperature</b>	40 °C   104 °F
<b>Average Power, Inner Conductor Temperature</b>	100 °C   212 °F
<b>Climatic Sequence Test Method</b>	IEC 60068-1
<b>Corrosion Test Method</b>	IEC 60068-2-11
<b>Damp Heat Steady State Test Method</b>	IEC 60068-2-3
<b>Immersion Depth</b>	1 m
<b>Immersion Test Mating</b>	Mated
<b>Immersion Test Method</b>	IEC 60529:2001, IP68
<b>Thermal Shock Test Method</b>	IEC 60068-2-14
<b>Vibration Test Method</b>	IEC 60068-2-6

## Packaging and Weights

<b>Weight, net</b>	125.06 g   0.276 lb
--------------------	---------------------

## Regulatory Compliance/Certifications

<b>Agency</b>	<b>Classification</b>
ISO 9001:2015	Designed, manufactured and/or distributed under this quality management system



# 400PDM-C

---

## \* Footnotes

**Insertion Loss, typical** 0.05v-freq (GHz) (not applicable for elliptical waveguide)

**Immersion Depth** Immersion at specified depth for 24 hours

# CNT-400-DB

---



CNT-400-DB, CNT® 50 Ohm Braided Coaxial Cable, flooded, black PE jacket

## Product Classification

<b>Product Type</b>	Braided coaxial cable
<b>Product Brand</b>	CNT®
<b>Product Series</b>	CNT-400

## General Specifications

<b>Braid Coverage</b>	86 %
<b>Cable Type</b>	CNT-400
<b>Jacket Color</b>	Black

## Dimensions

<b>Diameter Over Dielectric</b>	7.24 mm   0.285 in
<b>Diameter Over Jacket</b>	10.29 mm   0.405 in
<b>Diameter Over Tape</b>	7.391 mm   0.291 in
<b>Inner Conductor OD</b>	2.74 mm   0.108 in
<b>Outer Conductor OD</b>	8.08 mm   0.318 in
<b>Nominal Size</b>	0.400 in

## Electrical Specifications

<b>Cable Impedance</b>	50 ohm
<b>Capacitance</b>	78 pF/m   23.774 pF/ft
<b>dc Resistance, Inner Conductor</b>	4.49 ohms/km   1.369 ohms/kft
<b>dc Resistance, Outer Conductor</b>	5.61 ohms/km   1.71 ohms/kft
<b>dc Test Voltage</b>	2500 V
<b>Jacket Spark Test Voltage (rms)</b>	4000 V
<b>Maximum Frequency</b>	16.2 GHz

# CNT-400-DB

---

<b>Operating Frequency Band</b>	30 – 6000 MHz
<b>Peak Power</b>	16 kW
<b>Shielding Effectiveness</b>	90 dB
<b>Velocity</b>	85 %

## Attenuation

<b>Frequency (MHz)</b>	<b>Attenuation (dB/100 m)</b>	<b>Attenuation (dB/100 ft)</b>
30.0	2.49	0.76
50.0	3.18	0.97
150.0	4.92	1.5
220.0	6.23	1.9
450.0	8.86	2.7
900.0	12.8	3.9
1500.0	16.7	5.1
1800.0	18.4	5.6
2000.0	19.4	5.9
2400.0	21.65	6.6
2500.0	22	6.7
3000.0	24.6	7.5
4000.0	28.87	8.8
4500.0	30.84	9.4
5000.0	32.81	10
5200.0	33.46	10.2
5500.0	34.78	10.6
5800.0	35.76	10.9
6000.0	36.42	11.1

## Material Specifications

<b>Braid Material</b>	Tinned copper
<b>Dielectric Material</b>	Foam PE
<b>Jacket Material</b>	PE
<b>Inner Conductor Material</b>	Copper-clad aluminum wire
<b>Shield Tape Material</b>	Aluminum

## Mechanical Specifications



# CNT-400-DB

---

<b>Minimum Bend Radius, single Bend</b>	25.4 mm   1 in
<b>Tensile Strength</b>	73 kg   160.937 lb
<b>Bending Moment</b>	0.7 N-m   6.196 in lb
<b>Flat Plate Crush Strength</b>	0.7 kg/mm   39.198 lb/in

## Environmental Specifications

<b>Installation temperature</b>	-40 °C to +85 °C (-40 °F to +185 °F)
<b>Operating Temperature</b>	-40 °C to +85 °C (-40 °F to +185 °F)
<b>Storage Temperature</b>	-70 °C to +85 °C (-94 °F to +185 °F)
<b>Corrosion Protection</b>	Flooding compound
<b>Water Jetting Test Method</b>	GR-421-CORE, Section 4.3.5.1

## Packaging and Weights

<b>Cable weight</b>	0.07 kg/m   0.047 lb/ft
<b>Packaging Type</b>	Reel

## Regulatory Compliance/Certifications

<b>Agency</b>	<b>Classification</b>
ISO 9001:2015	Designed, manufactured and/or distributed under this quality management system

