

THIS DRAWING IS UNPUBLISHED. RELEASED FOR PUBLICATION
 © 2016 COMMScope, INC. CONFIDENTIAL NOTICE: THESE DRAWINGS AND SPECIFICATIONS ARE THE PROPRIETARY PROPERTY OF COMMScope, INC. AND MAY BE USED ONLY FOR THE SPECIFIC PURPOSE AUTHORIZED IN WRITING BY COMMScope, INC.

REVISIONS				
P	LTR	DESCRIPTION	DATE	APVD
A		RLSD; NPR NSD03-023	14APR03	GG PP
B		REV; ECO-07-022801	18OCT2007	GG SH
C		REV; ECO-09-013109	03JUN2009	GG DC
D		REV PER BNS_CD_BRAND	08FEB2017	GG DC

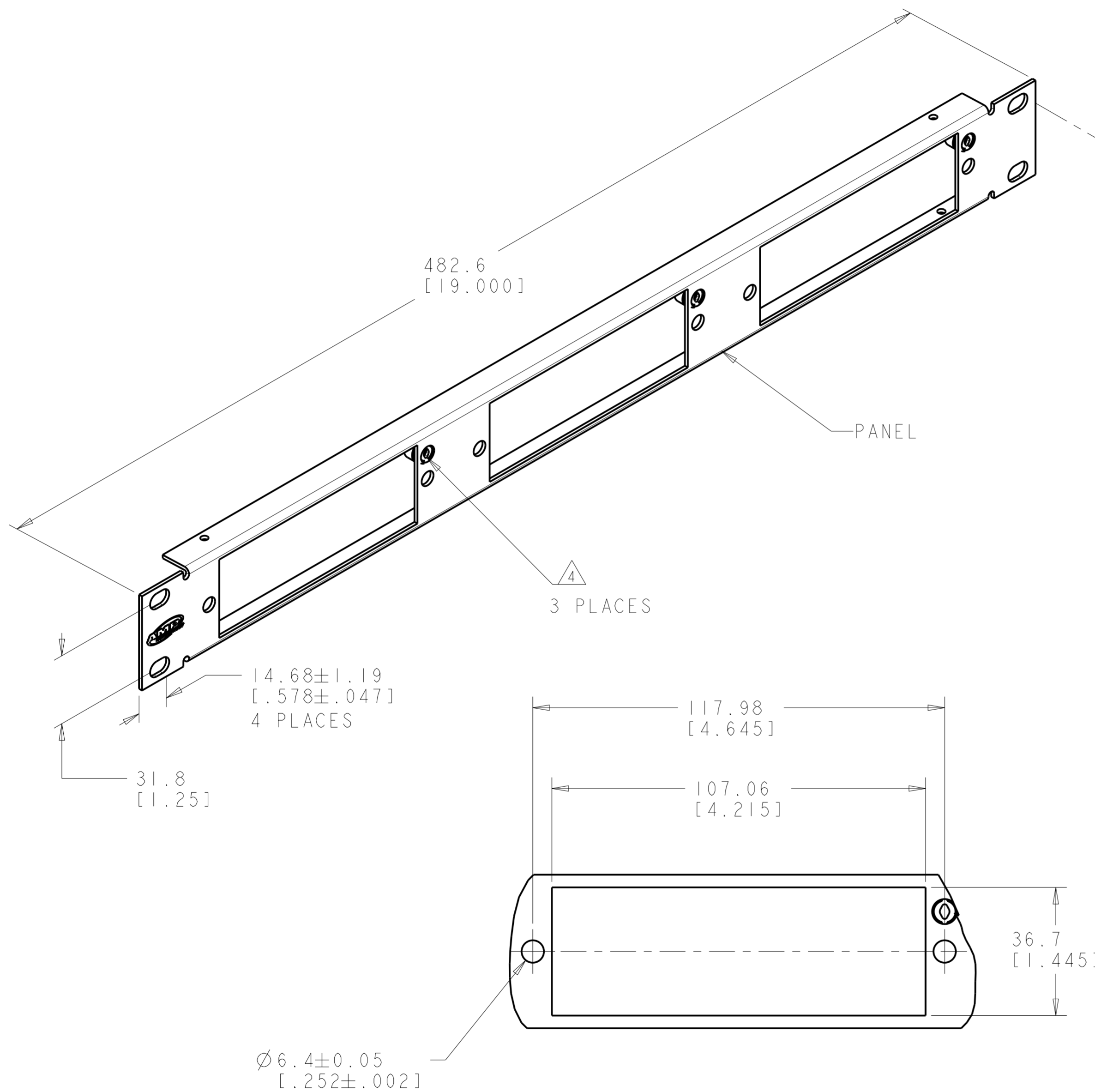

- 1 MATERIAL: PANEL - 16 AWG CARBON STEEL, BLACK. SCREWS - STAINLESS STEEL, BLACK.
- 2 DIMENSIONS ARE NOMINAL UNLESS NOTED OTHERWISE.
- 3 STARWASHERS PROVIDED LOOSE.
- 4 QUARTER TURN FASTENER, SHIELDED APPLICATION ONLY, 3 PLACES.

10-32 X 12.7 [.500] SCREWS, BAG OF 4
 12-24 X 12.7 [.500] SCREWS, BAG OF 4

1479451-1
 PART NUMBER

THIS DRAWING IS A CONTROLLED DOCUMENT.		DWN G. GARRETT 14APR03	COMMScope, INC.	
DIMENSIONS: MM [INCHES]		CHK P. PEPE 14APR03		
TOLERANCES UNLESS OTHERWISE SPECIFIED:		APVD P. PEPE 14APR03	NAME PATCH PANEL, 1U, 3-CASSETTE, MINI-RJ21	
0 PLC ±	1	PRODUCT SPEC	SIZE A2	CAGE CODE G-1479451
1 PLC ±	2	APPLICATION SPEC	SCALE 1:3	SHEET 1 OF 1
2 PLC ±	3	WEIGHT -	RESTRICTED TO -	
3 PLC ±	4	CUSTOMER DRAWING	REV D	
4 PLC ±	ANGLES			
FINISH				