

REVISIONS				
REV	LTN	DESCRIPTION	DATE	APPROV
C		REDWN/REV EC - 0B40-0081-03	02MAY2003	LHS SH
D		REV: EC 0B40-0181-03	07AUG03	GG SH
E		REV BNS.CD.BRAND	10FEB2017	GG DC

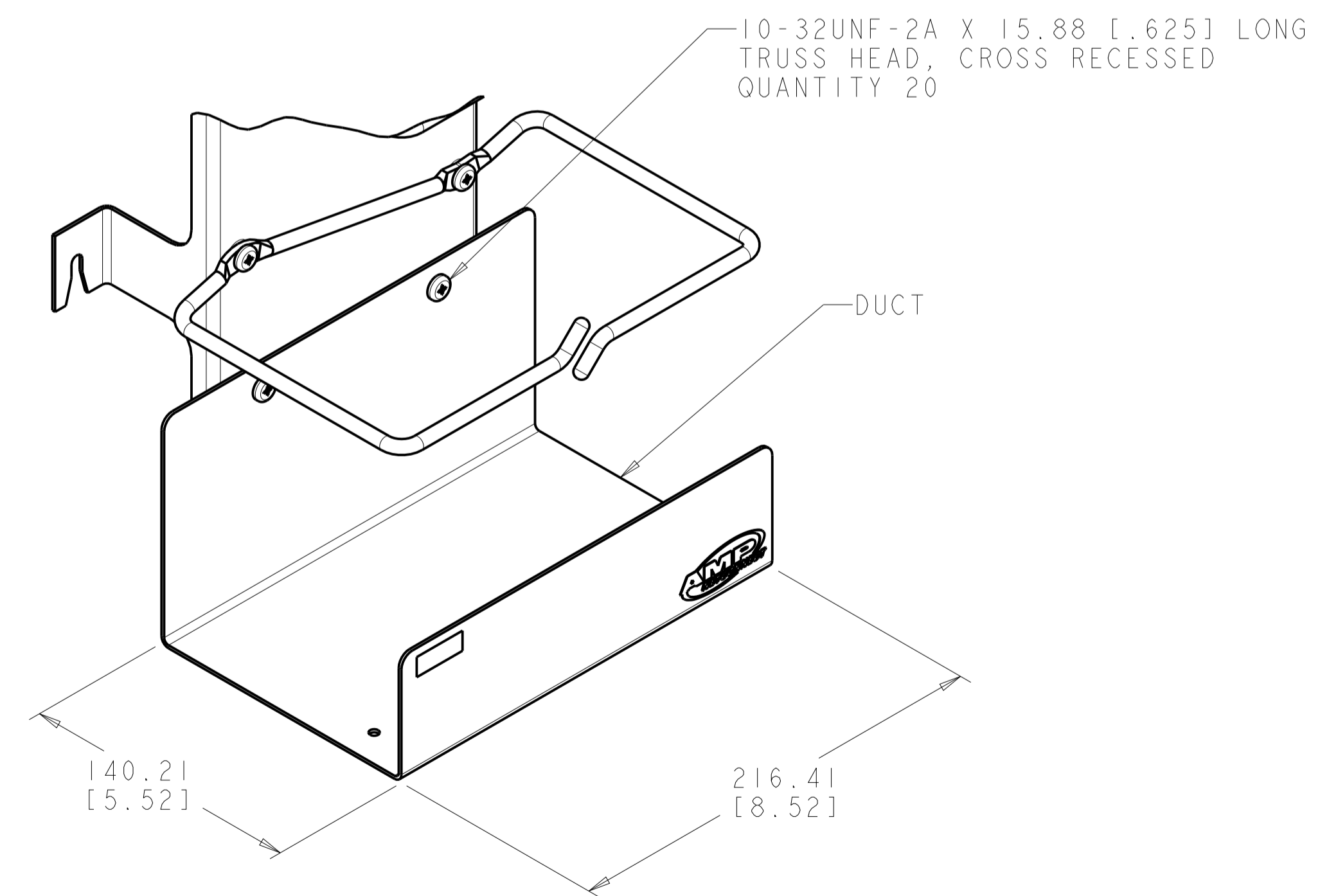
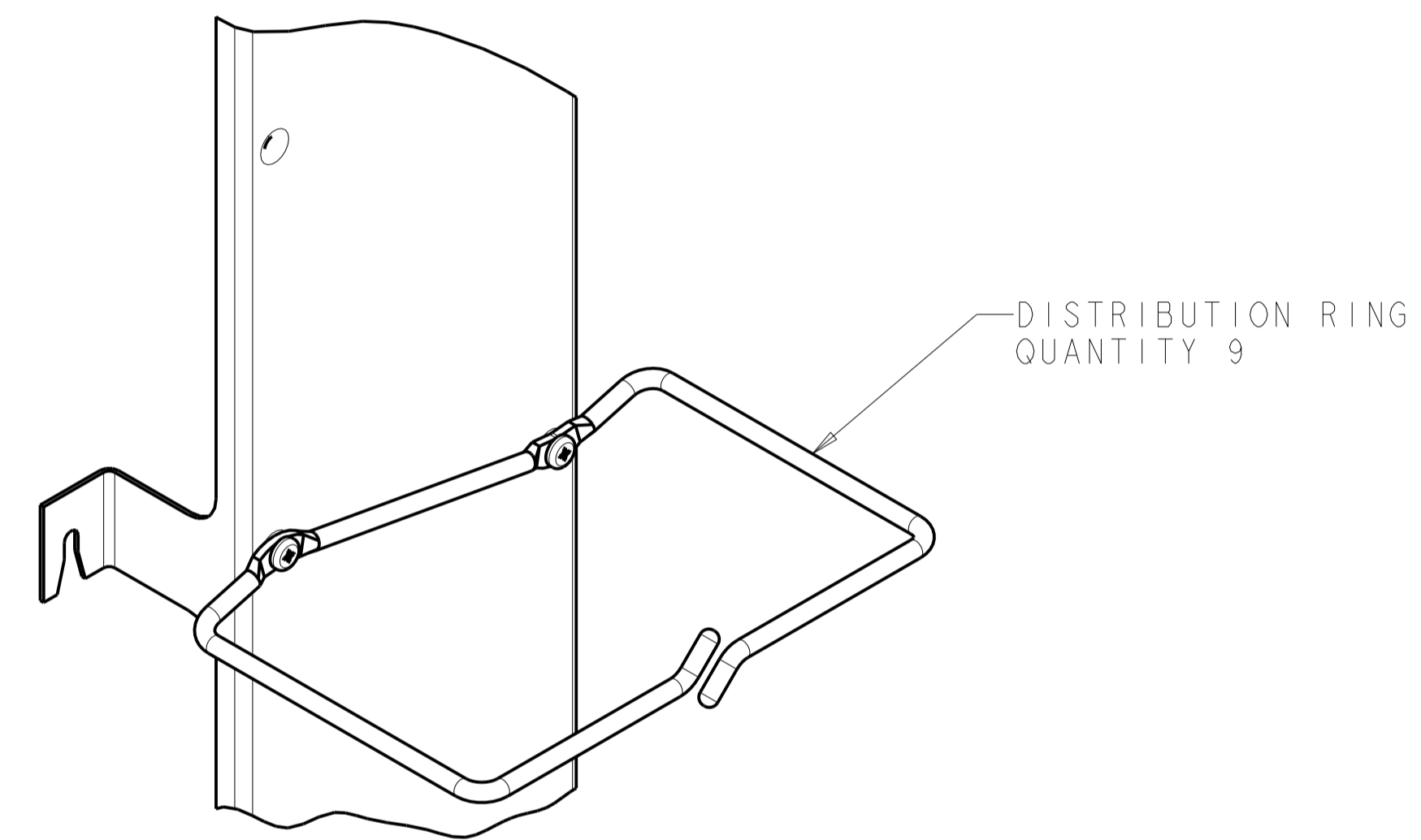
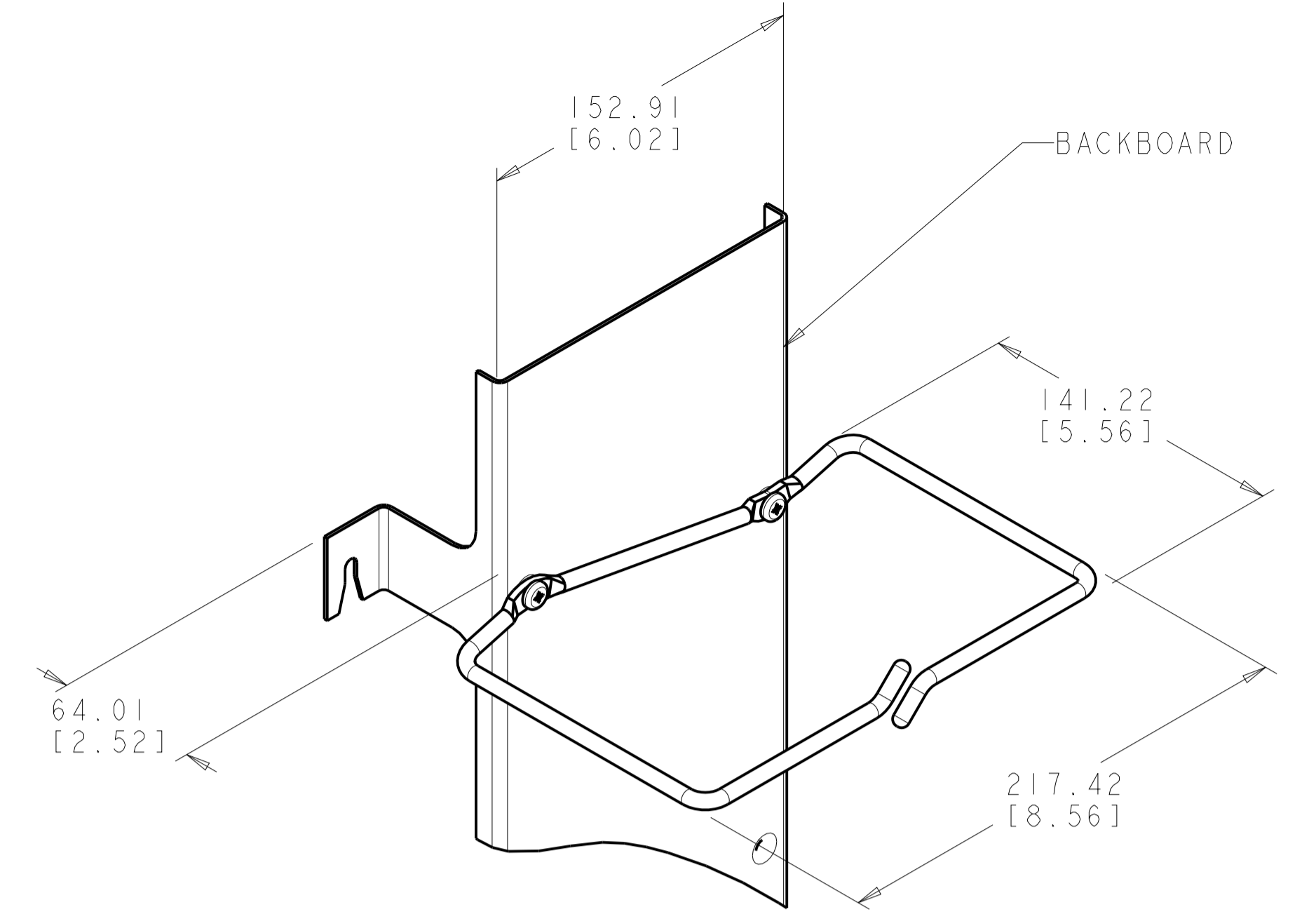

- 1 MATERIAL: BACKBOARD AND DUCT- CARBON STEEL, .062 THICK. DISTRIBUTION RING - ALUMINUM ALLOY, Ø.025, BLACK
- 2 DIMENSIONS ARE MAXIMUM UNLESS OTHERWISE SPECIFIED. OVERALL HEIGHT 1558.04 [61.34] MAXIMUM.
- 3 FINISH: LT ALMOND.
- 4 FINISH: BLACK

4	BLACK	569852-3
3	LT. ALMOND	569852-1
	DESCRIPTION	PART NUMBER

THIS DRAWING IS A CONTROLLED DOCUMENT.		DWN L. SMITH 02MAY2003	COMMSCOPE, INC.	
DIMENSIONS: MM [INCHES]		CHK L. SMITH 02MAY2003		
TOLERANCES UNLESS OTHERWISE SPECIFIED:		APVD S. HERNDON 02MAY2003	NAME VERT MGT BACKBOARD ASSY, 110 XCONN, 900 PAIR	
0 PLC ±	1	PRODUCT SPEC	SIZE CAGE CODE DRAWING NO RESTRICTED TO	
2 PLC ±	2	APPLICATION SPEC	A 1 C=569852	
3 PLC ±	3	WEIGHT	SCALE 1:2 SHEET 1 OF 1 REV E	
4 PLC ±	4	CUSTOMER DRAWING		
ANGLES ±				
MATERIAL	FINISH			