

REV	MCO	DWN	DATE
D	BNS_CD_BRAND	GG	10-FEB-17

NOTES:

1.0 SCOPE

THIS SPECIFICATION DEFINES THE REQUIREMENTS FOR A WALL PLATE MODULAR 12 PORT ASSY VARIOUS COLORS

2.0 APPLICABLE DOCUMENTS

- 2.1 UL 94 "TESTS FOR FLAMMABILITY OF PLASTIC MATERIALS"
- 2.2 ORDER OF PRECEDENCE

IN CASE OF CONFLICT, THE FOLLOWING ORDER OF PRECEDENCE SHALL APPLY:

- A. PURCHASE ORDER
- B. THIS DOCUMENT

3.0 REQUIREMENTS

3.1 MATERIALS

- 3.1.1 MATERIAL: ABS POLYLAC PA-765A OR EQUIVALENT.
- 3.1.2 COLOR: SEE TAB

3.2 DIMENSIONAL

- 3.2.1 SEE DRAWING
- 3.2.2 PART TO BE FREE OF BURRS, SCRATCHES, SPOTS AND NOTICEABLE SINK.

3.3 FLAMMABILITY:

- 3.3.1 FLAMMABILITY RATING: MATERIAL USED SHALL BE UL94 V-0 LISTED.

3.4 MARKING AND MOLDING:

- 3.4.1 CLASSIFIED U.S. UL LOGO, CLASSIFIED CANADA UL LOGO, UP ARROW DIRECTION, CATALOG NUMBER AND ADC LOGO, SHOULD BE MOLDED INSIDE THE FACE PLATE.

4.0 QUALITY ASSURANCE PROVISIONS:

4.1 MANUFACTURING INSPECTION:

THE MANUFACTURER SHALL PERFORM AUDITS TO ENSURE 100% FUNCTIONALITY OF ALL RECEIVED PARTS. ADDITIONAL TESTING AND INSPECTIONS SHALL BE PERFORMED AS NEEDED TO ENSURE THAT ALL REQUIREMENTS ARE MET.

4.2 QUALITY CONFORMANCE INSPECTION

BUYER RESERVES THE RIGHT TO RETURN AT THE MANUFACTURER'S EXPENSE ANY NONCONFORMING MATERIALS OR LOTS WHICH DO NOT MEET SAMPLING INSPECTION REQUIREMENTS.

4.3 DESIGN AND PROCESS CHANGE:

NO CHANGES IN MATERIAL DESIGN OR PROCESS WHICH WILL AFFECT FORM, FIT OR FUNCTION SHALL BE MADE BY THE MANUFACTURER AFTER SAMPLE APPROVAL WITHOUT WRITTEN AUTHORITY FROM THE BUYER. THE TERM "FUNCTIONAL" IMPLIES SECTION 3.0 PARAMETERS.

5.0 PACKAGING AND HANDLING REQUIREMENTS:

- 5.1 MAXIMUM CONTAINER WEIGHT: 40 LBS.
- 5.2 SHIPPING CONTAINER MARKING(S)

SHIPPING CONTAINERS SHALL BE MARKED WITH THE FOLLOWING AS A MINIMUM:

1. MANUFACTURER'S NAME AND/OR LOGO
2. ADC PART NUMBER
3. ADC PURCHASE ORDER NUMBER
4. QUANTITY ENCLOSED
5. (PREFERRED BUT OPTIONAL INFORMATION):
NUMBER OF SEPARATE PACKAGES/BOXES
("BOX# ---- OF ---- BOXES")

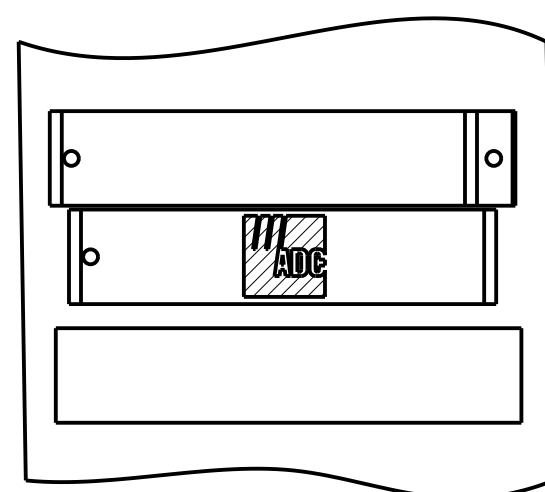

F/N 005 DETAIL

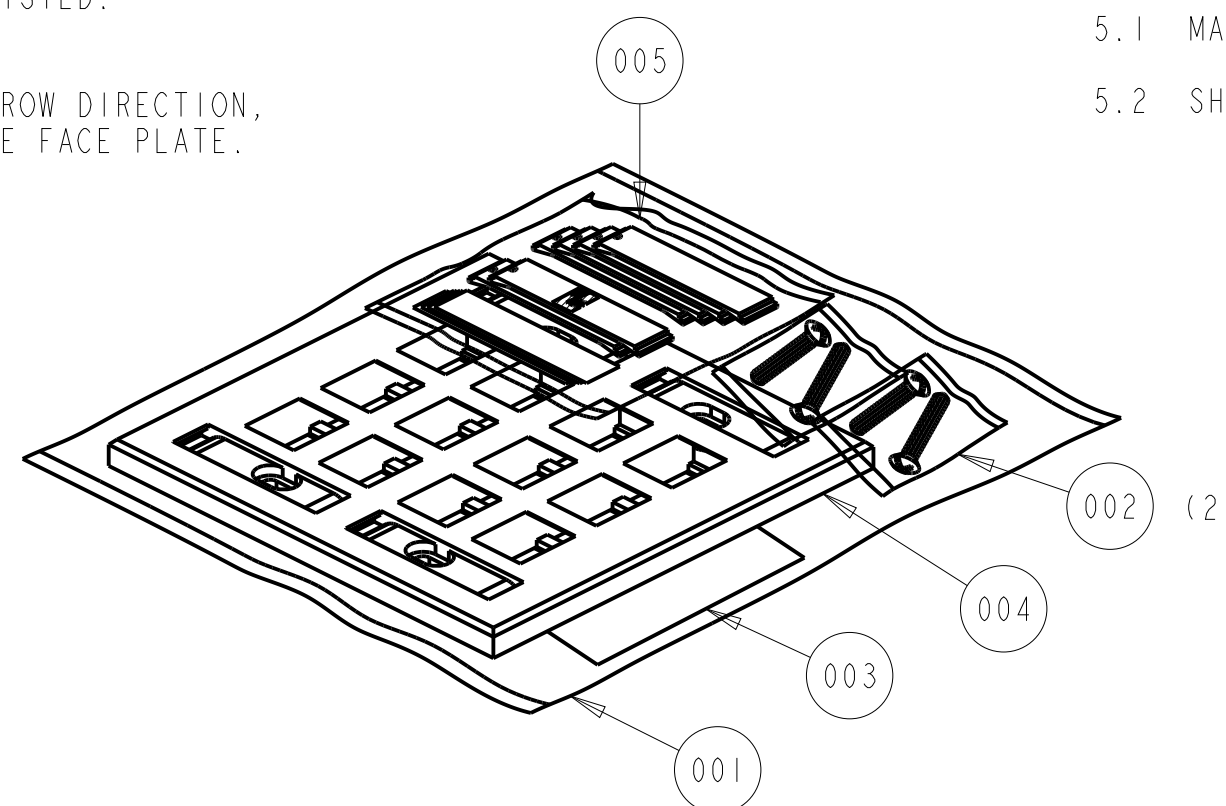

ADC P/N	CATALOG	REV	COMPONENT F/N 002 (DESCRIPTION) QTY 2	COMPONENT F/N 003 INST SHT 12 PORT WALL PLATE (COLOR) QTY 1	COMPONENT F/N 004 WALL PLATE, MODULAR 12 PORT (COLOR) QTY 1	PANTONE COLOR	FEDERAL STANDAR SPECIFICATION	COMPONENT F/N 005 POLYBAG DESIGNATION (COLOR) QTY 1
6644115701	6644 I 157-01	B	6630 3 105-00 POLYBAG W/2 #6 - 32x15/16 COMBO SCREWS	1436364	6644 3 157-01 (WHITE)	---	FED STD. 37925	6630 2 101-01 (WHITE)
6644115702	6644 I 157-02	B			6644 3 157-02 (IVORY)	---	FED STD. 27886	6630 2 101-02 (IVORY)
6644115703	6644 I 157-03	B			6644 3 157-03 (GRAY)	421C	FED STD. 25630	6630 2 101-03 (GRAY)
6644115704	6644 I 157-04	B			6644 3 157-04 (BLACK)	6C2X	FED STD 27038	6630 2 101-04 (BLACK)
6644115705	6644 I 157-05	B			6644 3 157-05 (RED)	187C	FED STD 11350	6630 2 101-05 (RED)
1340292	6644 I 157-22	C			6644 3 157-22 (ELECTRIC IVORY)	4545U	---	6630 2 101-22 (ELECTRIC IVORY)

NOTES:

- 1. USE POLYBAG CLEAR F/N 001 5 X 9 IN 0.002 THICK FOR PACKAGE ALL THESE COMPONENTS; IT SHOULD BE SEALED AT BOTH ENDS

COMMSCOPE, INC.

© 2016 COMMSCOPE, INC. CONFIDENTIAL
NOTICE: THESE DRAWINGS AND SPECIFICATIONS ARE THE PROPRIETARY PROPERTY OF COMMSCOPE, INC. AND MAY BE USED ONLY FOR THE SPECIFIC PURPOSE AUTHORIZED IN WRITING BY COMMSCOPE, INC.

ALL DIMS AND TOLERANCES .XX:±N/A
ARE INCHES UNLESS .XXX:±N/A
OTHERWISE SPECIFIED ANGULAR:±N/A

DO NOT SCALE DRAWING

ENGR: ERIC RICHARDS
DWN: ERIC RICHARDS

TITLE ASSY WALL PLATE
MODULAR 12 PORT

DRAWING NUMBER
66441157XX_ADC

SHT. 1 OF 1

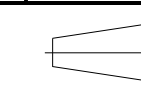
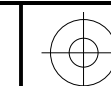

DIMENSIONS IN INCHES
THIRD ANGLE PROJECTION