

**Positive Lock Connectors (L2\*-PL)**

for HELIAX® LDF2-50 Coaxial Cable

Andrew Institute offers installation training

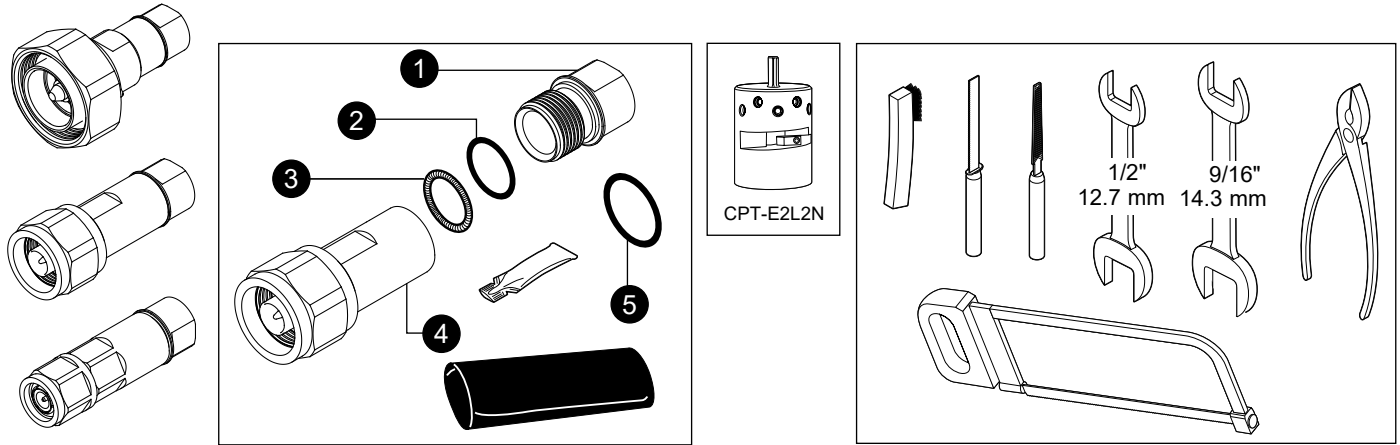

<p><b>1</b></p> <p>1-1/10" 28 mm</p> <p>Straighten cable. Remove jacket. 将电缆拉直，剥下护皮</p>	<p><b>2</b></p> <p>7/8" (22 mm)</p> <p>1 2 3 4 5</p> <p>Cut cable at top of corrugation, remove outer conductor, foam, and adhesive. 切除电缆波纹状外导管顶部，除去外导管、泡沫、和粘合剂。</p>	<p><b>3</b></p> <p>2</p> <p>1</p> <p>1 2 3 4 5</p> <p>Add O-ring, grease, clamp. 加O型圈，油脂。</p>	<p><b>4</b></p> <p>9/32" 6-7 mm</p> <p>1/32" 1 mm</p> <p>5</p> <p>Taper inner conductor. 锥形内心导体</p>
<p><b>1</b></p> <p>Straighten cable. Cut square. 将电缆拉直，垂直锯入</p>	<p><b>2</b></p> <p>Apply pressure until tool clicks. 施加压力直到工具发出啞声</p> <p><b>3</b></p> <p>Top of corrugation</p> <p>1 2 3 4 5</p> <p>Check the cut plane to ensure at the top of corrugation. If it's not at the top of corrugation, then needs to manually cut 1-2mm of inner conductor and use the tool re-trim cable as above shown. 检查切面确保在电缆波纹状外导管顶部，如果不在顶部，需手工切除内导体1-2mm，用电动工具重新剥线至上图所示。</p>	<p><b>4</b></p> <p>9/32" 6-7 mm</p> <p>2</p> <p>1</p> <p>1 2 3 4 5</p> <p>Add O-ring, grease, clamp. 加O型圈，油脂。</p> <p>5</p>	
<p><b>5</b></p> <p>Add O-ring, grease, and spring ring. 加O型圈，油脂，加弹簧圈。</p> <p>5</p> <p>3</p>	<p><b>6</b></p> <p>Trim the foam which high than outer conductor's cut plane; Deburr, include inside &amp; outside edge of outer conductor. 切除高出外导体表面的泡沫，去除外导体内外侧毛刺。</p>	<p><b>7</b></p> <p>Compress foam and flare outer conductor. 压紧泡沫塑料和电缆外导体扩口。</p> <p>Foam no high than outer conductor</p>	

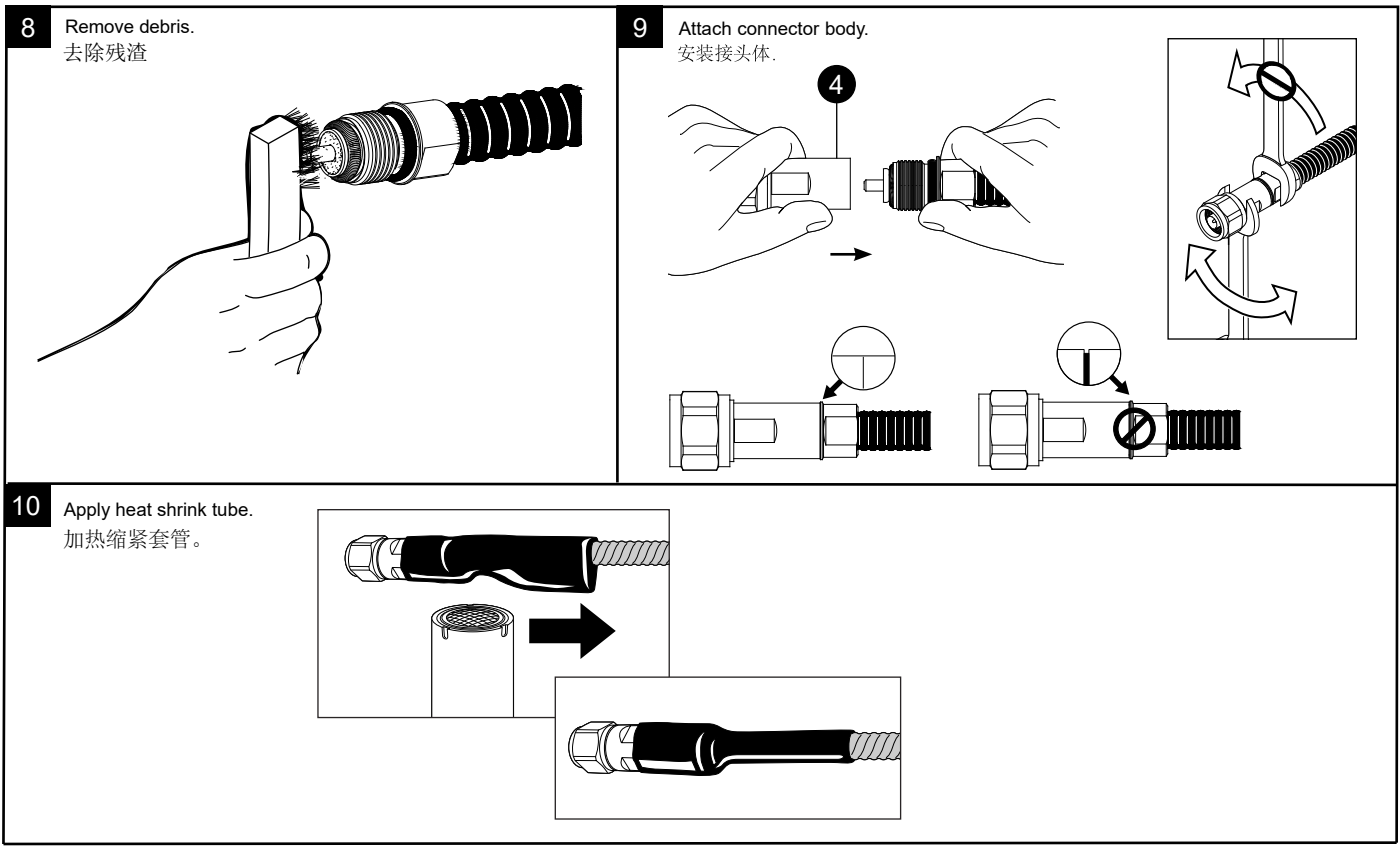

**Coupling Torque.**  
配合扭矩.

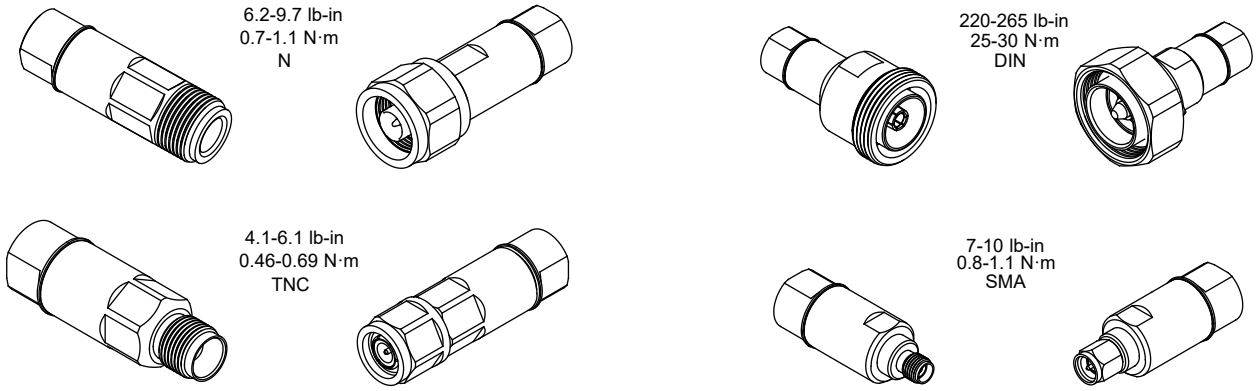

	表一 有毒有害物质或元素名称及含量标识格式					
	有毒有害物质或元素					
部件名称 (Part Name)	铅 (Pb)	汞 (Hg)	镉 (Cd)	六价铬 (Cr6+)	多溴联苯 (PBB)	多溴二苯醚 (PBDE)
连接器 (Connector)	X	O	O	O	O	O
O: 表示有毒有害物质在该部件所有的均质材料中的含量均在SJ/T 11363-2006规定的限量要求以下。 X: 表示该有毒有害物质至少在该部件的某一均质材料中的含量超出SJ/T 11363-2006规定的限量要求。						

**ANDREW an Amphenol company**  
2601 Telecom Parkway, Richardson, Texas, 75082, USA  
www.andrew.com

**Technical Support**  
+1 888 297 6433, Option 3 (Toll Free US and Canada)  
awpnarsupport@andrew.com

Notice: ANDREW disclaims any liability or responsibility for the results of improper or unsafe installation, inspection, maintenance, or removal practices.  
 Aviso: ANDREW no acepta ninguna obligación ni responsabilidad como resultado de prácticas incorrectas o peligrosas de instalación, inspección, mantenimiento o retiro.  
 Avis: ANDREW décline toute responsabilité pour les conséquences de procédures d'installation, d'inspection, d'entretien ou de retrait incorrectes ou dangereuses.  
 Hinweis: ANDREW lehnt jede Haftung oder Verantwortung für Schäden ab, die aufgrund unsachgemäßer Installation, Überprüfung, Wartung oder Demontage auftreten.  
 Atenção: A ANDREW abdica do direito de toda responsabilidade pelos resultados de práticas inadequadas e sem segurança de instalação, inspeção, manutenção ou remoção.  
 Avvertenza: ANDREW declina eventuali responsabilità derivanti dall'esecuzione di procedure di installazione, ispezione, manutenzione e smontaggio improprie o poco sicure.  
 注意: ANDREW 公司申明對於不恰當或不安全的安裝、檢驗、維修或拆卸操作所導致的後果不負責任 何義務和責任

