

# Installation Instructions

## Connector Attachment

For Braided Cable CNT-195  
TNC Female, Captivated Pin,  
Crimp-type Body: 195PTF-C-CR

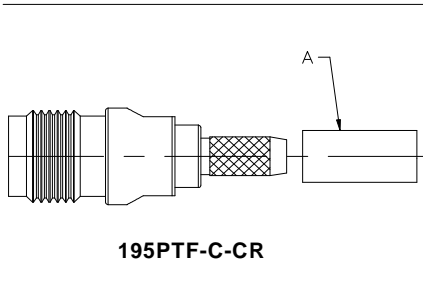

**1** Remove 16.0 mm (0.630") of Jacket only.

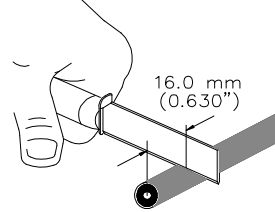

**2** Trim 5.0 mm (0.197") of braid, exposing foil & foam.

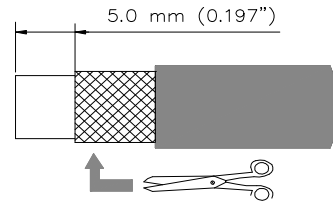

**3** Remove 5.0 mm (0.197") of foam, exposing center conductor.

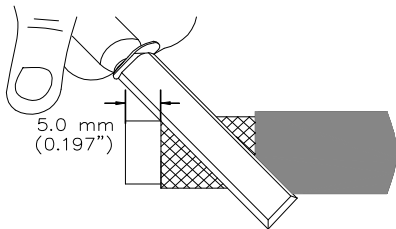

**4** Chamfer the center conductor at a 45° angle.

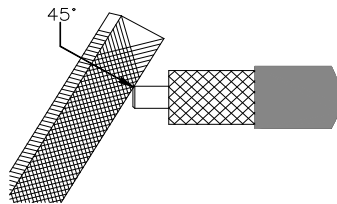

**5** Slide part A onto cable, splay out braid as shown.

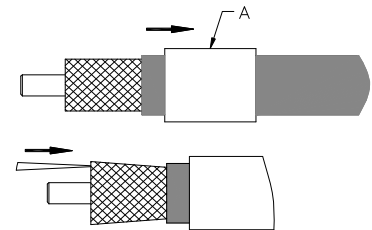

**6** The cable attachment must be straight and aligned with the hole of connector inner contact. Insert the cable attachment into connector body until stopped; the cable center conductor must be inserted into inner contact fingers. Make sure the braid cover on body sleeve and push part A onto braid.

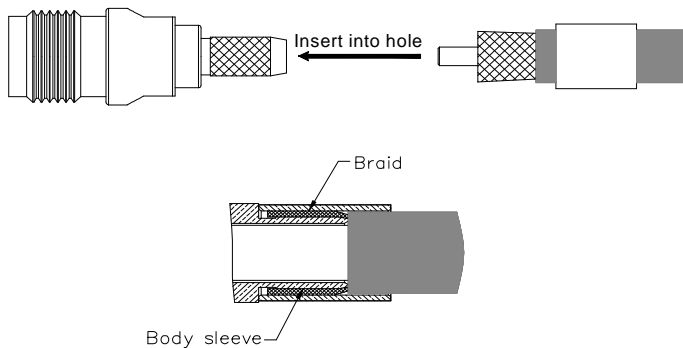

**7** Crimp the ferrule at the area as shown. Crimp tool part number is: CTBC-2.

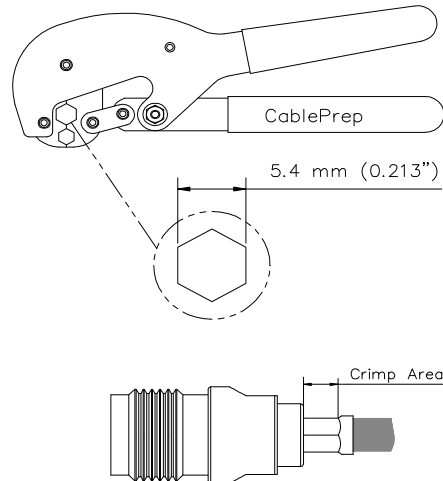

	表一 有毒有害物质或元素名称及含量标识格式					
	有毒有害物质或元素					
部件名称 (Part Name)	铅 (Pb)	汞 (Hg)	镉 (Cd)	六价铬 (Cr6+)	多溴联苯 (PBB)	多溴二苯醚 (PBDE)
连接器 (Connector)	X	O	O	O	O	O

O: 表示有毒有害物质在该部件所有的均质材料中的含量均在SJ/T 11363-2006规定的限量要求以下。  
X: 表示该有毒有害物质至少在该部件的某一均质材料中的含量超出SJ/T 11363-2006规定的限量要求。

Installation Training Available at Andrew Institute

Notice: Andrew disclaims any liability or responsibility for the results of improper or unsafe installation, in spection, maintenance, or removal practices



**Andrew Corporation**  
3 Westbrook Corporate Center, Suite 900, Westchester, Illinois U.S.A. 60154  
+1 (708) 349-3300 Fax (U.S.A.): 1-800-349-5444  
www.andrew.com

**Customer Service, 24 hours**  
U.S.A., Canada, Mexico: 1-800-255-1479  
U.K.: 0800 250055  
Other Europe: +44 592 782 612

