

F4HM-D, F4HF-D, F4HR-D, F4DM-D Connector Installation for HELIAX® FSJ4 Cables

Bulletin 7718500 Revision H Page 1 of 2



CommScope Infrastructure Academy offers installation training.



Scan For
Installation Video

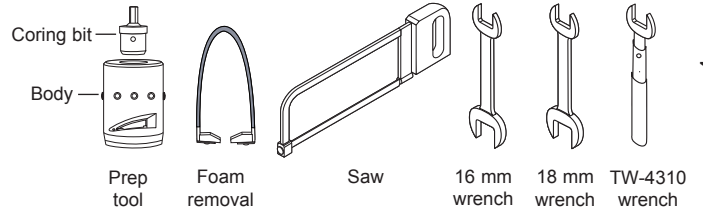
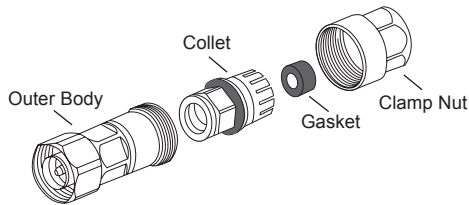

1 Straighten the cable and cut the end square using saw.

6 in (152 mm)

90°

WARNING
Outer conductor edges will be sharp

Recommended 40TPI or higher

2 Apply forward pressure until the tool bottoms out. Reverse tool to remove.

Prep tool
CPT-F4-D required

0.39 in (10 mm)

DO NOT REMOVE FOAM FROM INNER

Operating drill speed
250-650 rpm range

3 If all the outer jacketing wasn't removed during initial cable prep remove at this time. Slide clamping nut over the cable end. Clean face of foam outer conductor with included alcohol wipe. Install the gasket leaving a 3 mm gap between the jacketing and the gasket. End of the prep tool can be used as a guide.

0.12 in (3 mm)

Prep Tool

4 Apply a thin layer of grease to the gasket. Slide the collet over the gasket until it stops, then thread onto the corrugations and use a 16 mm wrench on the collet flats rotating until 2.4 mm of outer extends past the face of the collet. Pull outer body to remove coring bit from the tool and use guide mark to verify outer length.

0.095 in (2.4 mm)

Coring Bit

5 To achieve optimum Return Loss, place coring bit over inner conductor and push forward until bit contacts face of foam. **BEFORE turning drill push HARD depressing foam.** Maintaining force, turn drill at 1/4 trigger until tool bottoms out. Clean foam from coring bit and repeat, carefully remove any loose foam with non-metallic tool.

4 MAX

6 Remove the foam dielectric and any excess adhesive on inner conductor up to the end of outer conductor using provided foam removal tool. Squeeze the tool at base of inner conductor and pull forward.



F4HM-D, F4HF-D, F4HR-D, F4DM-D Connector Installation for HELIAX® FSJ4 Cables

Bulletin 7718500 Revision H Page 2 of 2



CommScope Infrastructure Academy offers installation training.

7



WARNING

To achieve optimum PIM, use included alcohol wipe on the exposed inner, outer and remaining foam on the inner to remove any remaining particles. **Do not remove foam from inner.** Carefully examine ends of outer and inner conductors. If cuts are not clean or either conductor looks scratched, damaged or distorted, remove components, cut off cable and refit.

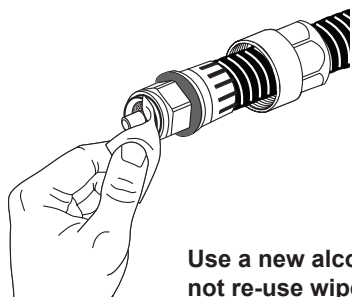

Use a new alcohol wipe. Do not re-use wipe from step #3.

Tip: A bright flashlight can help detect particles and clean pressurized air can be useful to blow out the particles.

8

Slide the outer body over the collet and rotate slightly to align socket within the outer body with the hex edge on the collet. Push until fully engaged.

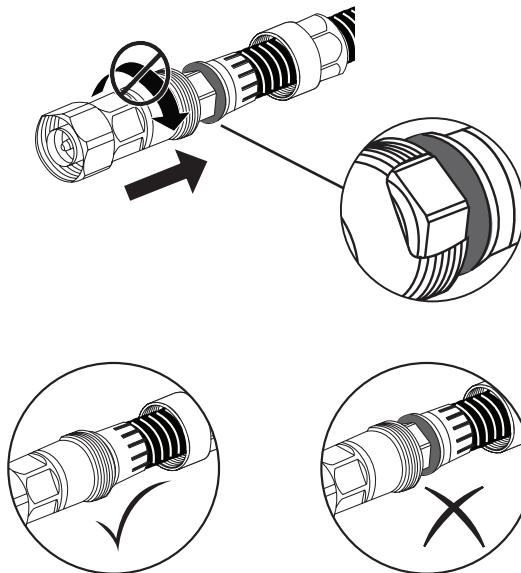

9

Slide the clamping nut up to the outer body and tighten by hand by turning the clamping nut and holding the front body stationary. Complete the installation by tightening with torque and open ended wrenches.

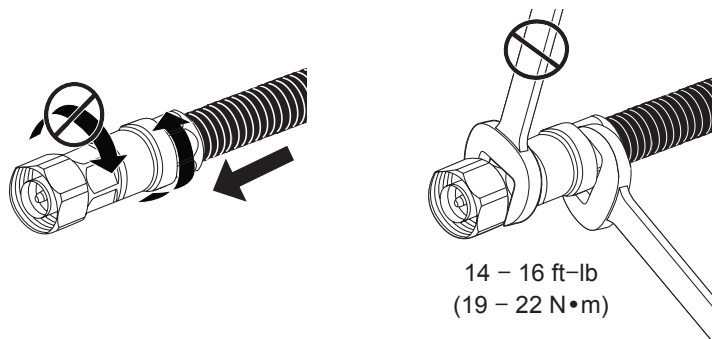

14 - 16 ft-lb
(19 - 22 N•m)

10

Tighten the coupling nut to the proper torque specification.

Torque wrench
Part Number:
TW-4310

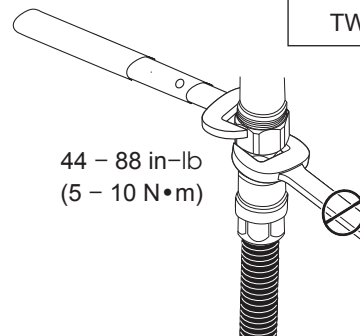

44 - 88 in-lb
(5 - 10 N•m)

CommScope

1100 CommScope Place SE P.O. Box 339, Hickory, NC 28603-0339
(828) 324-2200 (800) 982-1708
www.commscope.com

Customer Service 24 hours

North America: +1-800-255-1479 (toll free)
Any country: +1-779-435-6500
email: acicustomersupportcenter@commscope.com

Notice: CommScope disclaims any liability or responsibility for the results of improper or unsafe installation, inspection, maintenance, or removal practices.
Aviso: CommScope no acepta ninguna obligación ni responsabilidad como resultado de prácticas incorrectas o peligrosas de instalación, inspección, mantenimiento o retiro.
Avis : CommScope décline toute responsabilité pour les conséquences de procédures d'installation, d'inspection, d'entretien ou de retrait incorrectes ou dangereuses.
Hinweis: CommScope lehnt jede Haftung oder Verantwortung für Schäden ab, die aufgrund unsachgemäßer Installation, Überprüfung, Wartung oder Demontage auftreten.
Atenção: A CommScope abdica do direito de toda responsabilidade pelos resultados de práticas inadequadas e sem segurança de instalação, inspeção, manutenção ou remoção.
Avvertenza: CommScope declina eventuali responsabilità derivanti dall'esecuzione di procedure di installazione, ispezione, manutenzione e smontaggio improprie o poco sicure.
注意: CommScope 公司申明對於不恰當或不安全的安裝、檢驗、維修或拆卸操作所導致的後果不負責任。何義務和責任

