

NOTES:

REVISIONS			
REV.	DESCRIPTION	DATE	APPROVED
A	ECR 8000019123: REL TO PRODUCTION PER EAO 603580.	15JUL17 QF	YATEEN/VIJAY
B	ECR 8000026034: UPDATE THE DRAWING WITH LASTEST MODEL.	04SEP17 LS	YATEEN/VIJAY
C	ECR 8000026096: UPDATE THE DRAWING WITH LASTEST MODEL.	12SEP17 QF	S.LIU/JIHE

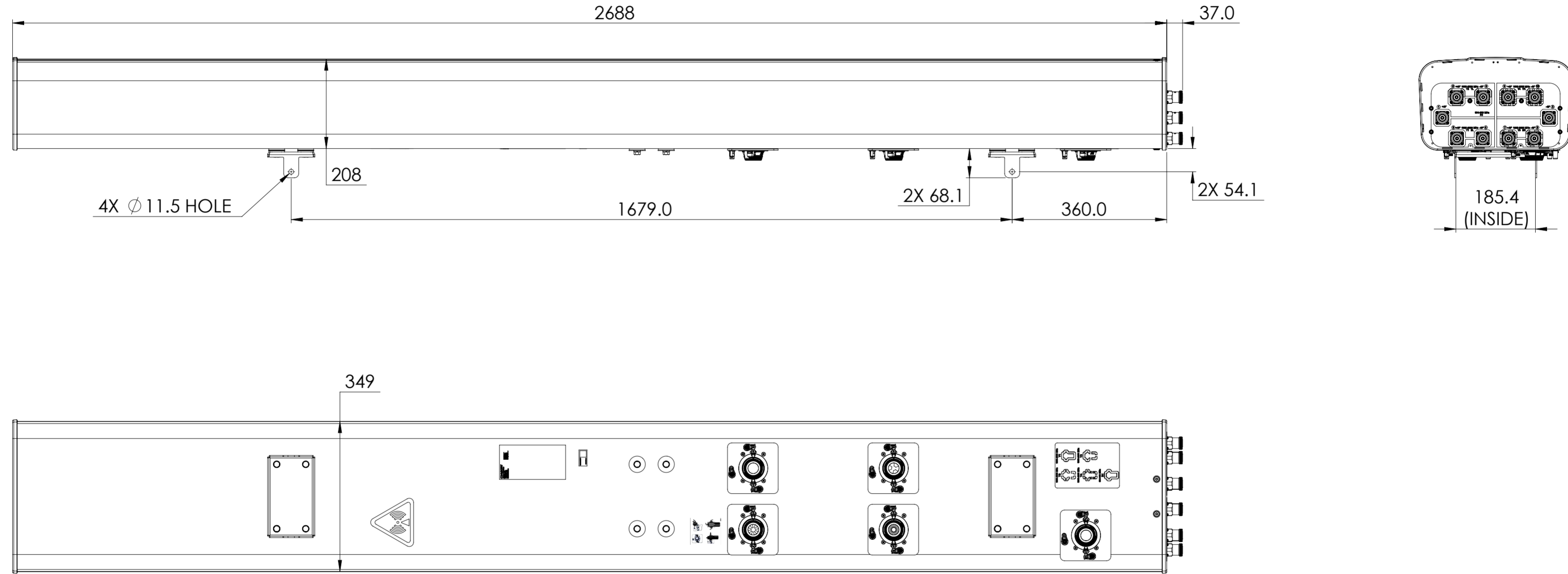

RV4-65D-M

<b>COMMScope, INC. OF NORTH CAROLINA</b>												
TOLERANCES						SAP MATERIAL MASTER						
0 PLACE X ±			2 PLACE .XX ±			1 PLACE .X ±			ANGLES ±			
FINISH						MATERIAL						
UNLESS OTHERWISE SPECIFIED DIMENSIONS ARE IN MILLIMETERS INTERPRET PER ISO STANDARDS HANDBOOK TECHNICAL DRAWINGS, VOLUMES 1 & 2, THIRD EDITION (2002)	NAME	DATE	TITLE									
	CE QF	15JUL17	<b>PRODUCT DRAWING</b>									
	RW QW1004	09/12/2017										
	RV CHALIU	09/18/2017										
	AD JIHE	09/20/2017										
RE BYUAN	09/20/2017											
ECN 8000026096-0			SCALE	DOCUMENT NO.								
			1:8	<b>RV4-65D-M-L</b>								
SIZE		WORK AREA	MODEL			DRAWING			SHEET			
<b>A2</b>			23			REVISION			1 OF 2			
			VERSION	STATUS	REVISION	VERSION	STATUS	REVISION				
			02	RE	C	02	RE	C				

DENSITY	g/mm <sup>3</sup>
MASS	grams
VOLUME	mm <sup>3</sup>
SURFACE AREA	mm <sup>2</sup>
HEIGHT	
LENGTH	
WIDTH	

© 2017 CommScope, Inc.

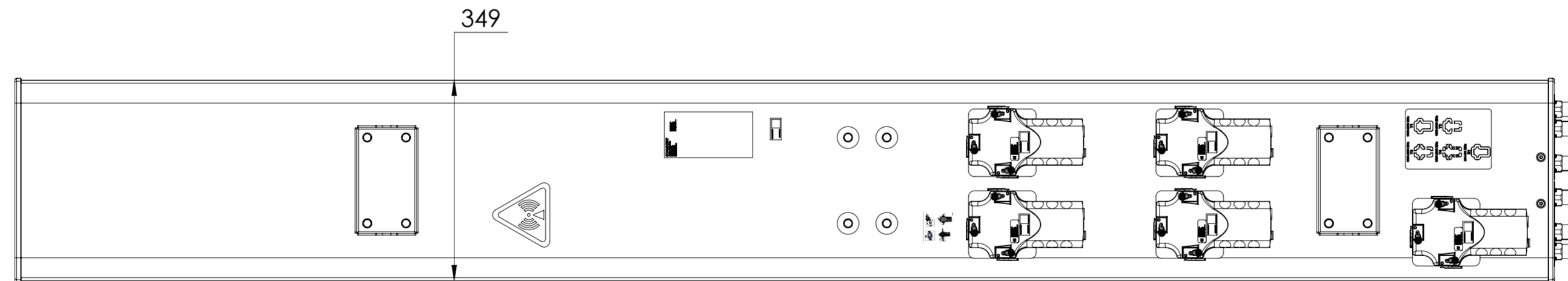
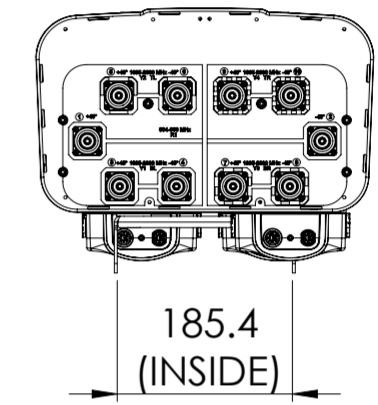

RV4-65D-ER5

COMMSCOPE, INC. OF NORTH CAROLINA				
TITLE PRODUCT DRAWING				
SIZE <b>A2</b>	SCALE <b>1:8</b>	DOCUMENT NO. RV4-65D-M-L		
DRAWING				SHEET
VERSION 02	STATUS RE	REVISION C	2 OF 2	