

REVISIONS			
REV.	DESCRIPTION	DATE	APPROVED
A	ECR 8000031411: REL TO PRODUCTION PER EAO 605740.	27NOV18 RY	KEL/REX
B	ECR 8000031411: UPDATE DRAWING WITH LATEST MODEL.	22DEC18 RY	KEL/REX
C	ECR 8000034728: UPDATE DRAWING WITH LATEST MODEL.	03APR19 ZW	KEL/REX

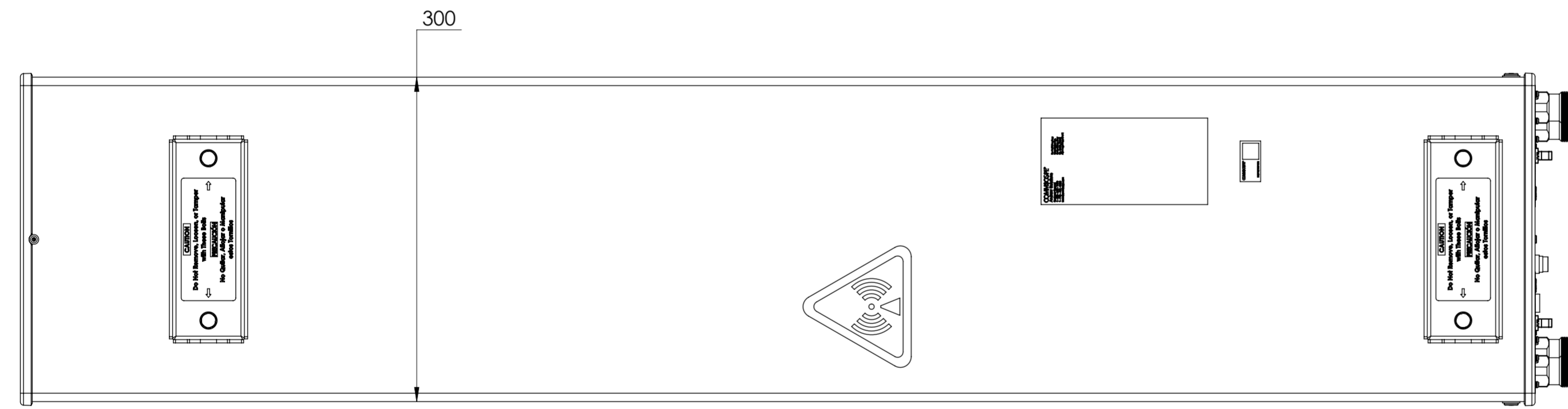
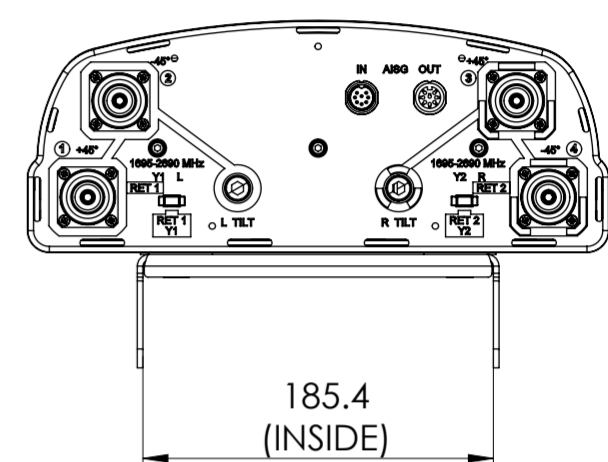
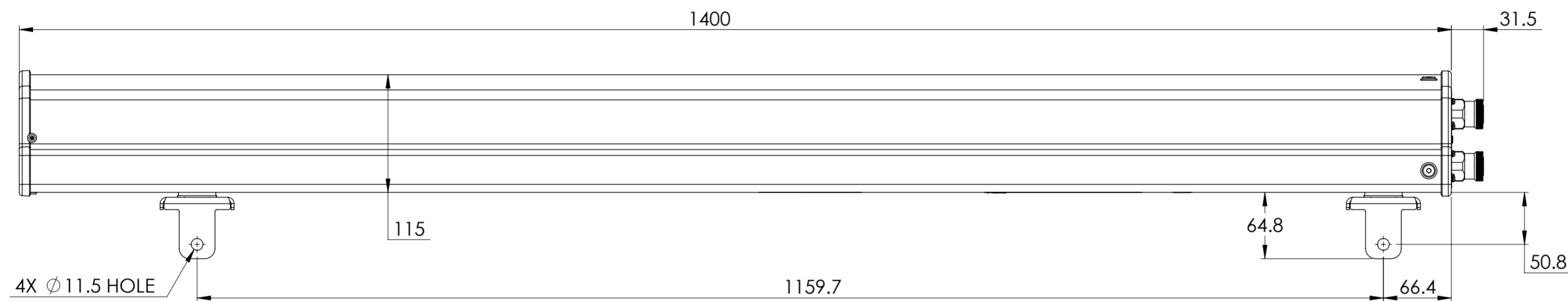

VV-65A-R2-V2

COMMSCOPE, INC. OF NORTH CAROLINA

TOLERANCES		SAP MATERIAL MASTER																																						
0 PLACE	X ±	2 PLACE	.XX ±																																					
1 PLACE	.X ±	ANGLES	±																																					
FINISH		MATERIAL																																						
PRODUCT DRAWING																																								
<table border="1"> <thead> <tr> <th>NAME</th> <th>DATE</th> <th>TITLE</th> </tr> </thead> <tbody> <tr> <td>CE RY1017</td> <td>11/27/2018</td> <td rowspan="5" style="text-align: center;">SCALE 1:4 DOCUMENT NO. VV-65A-R2-V2-L</td> </tr> <tr> <td>RW WZ1012</td> <td>04/03/2019</td> </tr> <tr> <td>RV WW1027</td> <td>04/04/2019</td> </tr> <tr> <td>AD YHUAN</td> <td>04/04/2019</td> </tr> <tr> <td>RE ZHHCHEN</td> <td>04/04/2019</td> </tr> </tbody> </table>		NAME	DATE	TITLE	CE RY1017	11/27/2018	SCALE 1:4 DOCUMENT NO. VV-65A-R2-V2-L	RW WZ1012	04/03/2019	RV WW1027	04/04/2019	AD YHUAN	04/04/2019	RE ZHHCHEN	04/04/2019	<table border="1"> <tr> <td>SIZE</td> <td>WORK AREA</td> <td>23</td> <td>MODEL</td> <td colspan="3">DRAWING</td> <td>SHEET</td> </tr> <tr> <td rowspan="2" style="font-size: 2em;">A2</td> <td rowspan="2"> </td> <td>VERSION</td> <td>STATUS</td> <td>REVISION</td> <td>VERSION</td> <td>STATUS</td> <td>REVISION</td> </tr> <tr> <td>02</td> <td>RE</td> <td>C</td> <td>02</td> <td>RE</td> <td>C</td> <td>1 OF 1</td> </tr> </table>		SIZE	WORK AREA	23	MODEL	DRAWING			SHEET	A2		VERSION	STATUS	REVISION	VERSION	STATUS	REVISION	02	RE	C	02	RE	C	1 OF 1
NAME	DATE	TITLE																																						
CE RY1017	11/27/2018	SCALE 1:4 DOCUMENT NO. VV-65A-R2-V2-L																																						
RW WZ1012	04/03/2019																																							
RV WW1027	04/04/2019																																							
AD YHUAN	04/04/2019																																							
RE ZHHCHEN	04/04/2019																																							
SIZE	WORK AREA	23	MODEL	DRAWING			SHEET																																	
A2		VERSION	STATUS	REVISION	VERSION	STATUS	REVISION																																	
		02	RE	C	02	RE	C	1 OF 1																																

DENSITY	g/mm ³
MASS	grams
VOLUME	mm ³
SURFACE AREA	mm ²
HEIGHT	
LENGTH	
WIDTH	