

### FAST-TDCD-N1/2-BCH *Fast Antenna Sealing Technology for Connector Protection*

- 1** Ensure cable and connector conform to diagram below. Installation temperature: -10 to 45 degrees C.

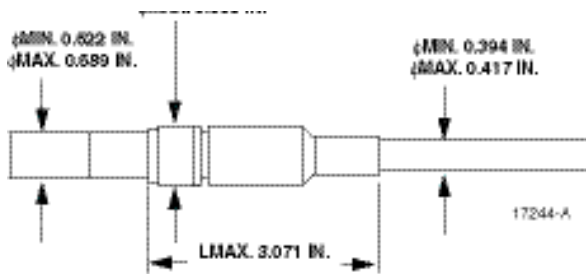

- 4** Put the connector into the enclosure properly. NOTE: Do not mis-align cable in enclosure. Do not bend cable in enclosure.

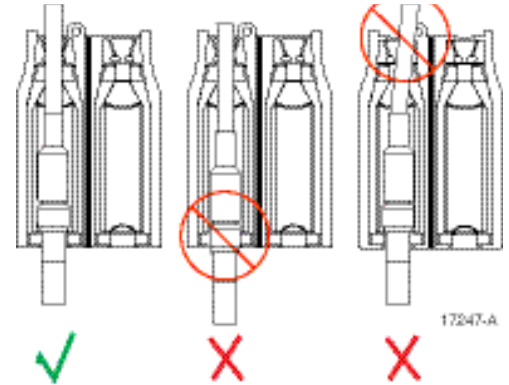

- 2** Clean connector and cable with cleaning tissue.

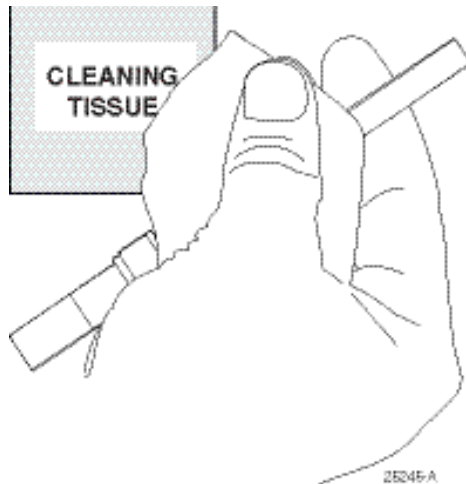

- 5** Slide on the wedge until it clicks.

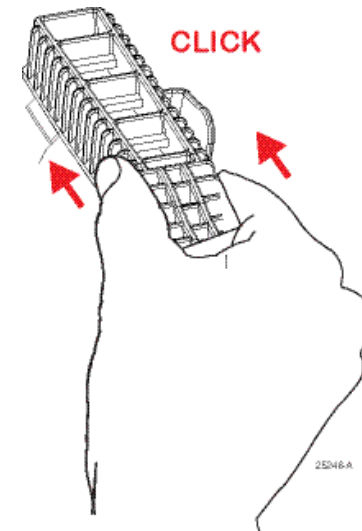

- 6** Keep the cable straight as shown.

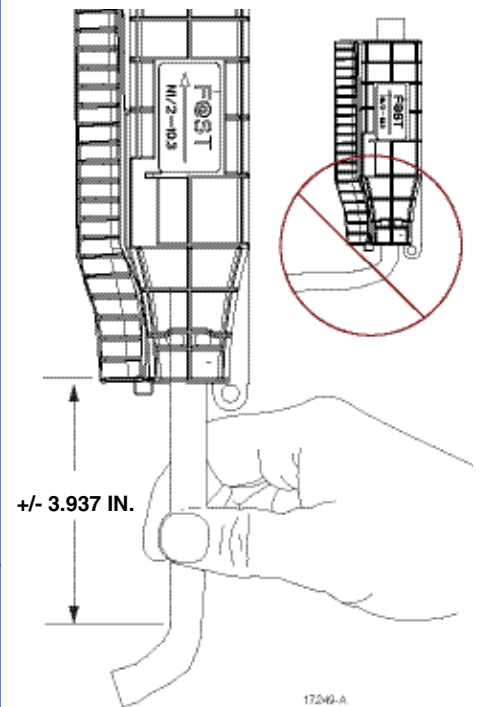

- 3** Smear oil on the gel.

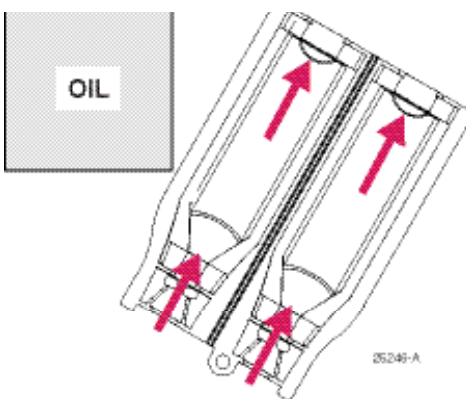

## COMMSCOPE®

TECHNICAL SUPPORT OR PRODUCT INFORMATION  
<http://www.commscope.com/SupportCenter/TechnicalSupport.aspx>  
 PATENTS  
<http://www.commscope.com/ProductPatent/ProductPatent.aspx>