

# AL5NM-PSA

---

Type N Male Positive Stop™ for 7/8 in AVA5-50 cable



## Product Classification

<b>Product Type</b>	Wireless and radiating connector
<b>Product Brand</b>	HELIAX®   Positive Stop™
<b>Product Series</b>	AVA5-50   AVA5RK-50
<b>Ordering Note</b>	ANDREW® non-standard product

## General Specifications

<b>Body Style</b>	Straight
<b>Cable Family</b>	AL5-50   AVA5-50
<b>Inner Contact Attachment Method</b>	Captivated
<b>Inner Contact Plating</b>	Silver
<b>Interface</b>	N Male
<b>Mounting Angle</b>	Straight
<b>Outer Contact Attachment Method</b>	Ring-flare
<b>Outer Contact Plating</b>	Trimetal
<b>Pressurizable</b>	No

## Dimensions

<b>Length</b>	63.25 mm   2.49 in
<b>Diameter</b>	37.08 mm   1.46 in
<b>Nominal Size</b>	7/8 in

## Outline Drawing

# AL5NM-PSA

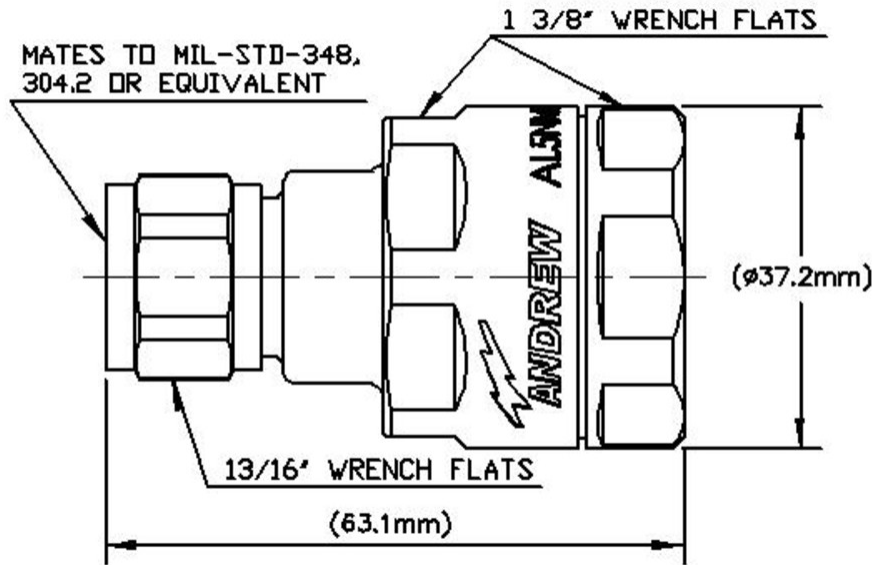

## Electrical Specifications

<b>3rd Order IMD at Frequency</b>	-116 dBm @ 910 MHz
<b>3rd Order IMD Test Method</b>	Two +43 dBm carriers
<b>Insertion Loss Coefficient, typical</b>	0.05
<b>Average Power at Frequency</b>	0.6 kW @ 900 MHz
<b>Cable Impedance</b>	50 ohm
<b>Connector Impedance</b>	50 ohm
<b>dc Test Voltage</b>	2000 V
<b>Inner Contact Resistance, maximum</b>	2 mOhm
<b>Insulation Resistance, minimum</b>	5000 MOhm
<b>Operating Frequency Band</b>	0 – 5200 MHz
<b>Outer Contact Resistance, maximum</b>	0.3 mOhm
<b>Peak Power, maximum</b>	10 kW
<b>RF Operating Voltage, maximum (vrms)</b>	707 V
<b>Shielding Effectiveness</b>	-130 dB

## VSWR/Return Loss

<b>Frequency Band</b>	<b>VSWR</b>	<b>Return Loss (dB)</b>
<b>50–1000 MHz</b>	1.023	38.89

# AL5NM-PSA

---

<b>1010–2200 MHz</b>	1.025	38.17
<b>2210–3000 MHz</b>	1.036	35.05
<b>3010–4000 MHz</b>	1.074	28.95
<b>4010–5200 MHz</b>	1.135	23.98

## Mechanical Specifications

<b>Attachment Durability</b>	25 cycles
<b>Connector Retention Tensile Force</b>	1,334.47 N   300 lbf
<b>Connector Retention Torque</b>	8.14 N-m   72.001 in lb
<b>Coupling Nut Proof Torque</b>	4.52 N-m   39.997 in lb
<b>Coupling Nut Retention Force</b>	444.82 N   100 lbf
<b>Coupling Nut Retention Force Method</b>	MIL-C-39012C-3.25, 4.6.22
<b>Insertion Force</b>	66.72 N   15 lbf
<b>Insertion Force Method</b>	MIL-C-39012C-3.12, 4.6.9
<b>Interface Durability</b>	500 cycles
<b>Interface Durability Method</b>	IEC 61169-16:9.5
<b>Mechanical Shock Test Method</b>	MIL-STD-202F, Method 213B, Test Condition C

## Environmental Specifications

<b>Operating Temperature</b>	-55 °C to +85 °C (-67 °F to +185 °F)
<b>Storage Temperature</b>	-55 °C to +85 °C (-67 °F to +185 °F)
<b>Attenuation, Ambient Temperature</b>	20 °C   68 °F
<b>Average Power, Ambient Temperature</b>	40 °C   104 °F
<b>Corrosion Test Method</b>	MIL-STD-1344A, Method 1001.1, Test Condition A
<b>Immersion Depth</b>	1 m
<b>Immersion Test Mating</b>	Unmated
<b>Immersion Test Method</b>	IEC 60529:2001, IP68
<b>Moisture Resistance Test Method</b>	MIL-STD-202F, Method 106F
<b>Thermal Shock Test Method</b>	MIL-STD-202F, Method 107G, Test Condition A-1, Low Temperature -55 °C
<b>Vibration Test Method</b>	IEC 60068-2-6
<b>Water Jetting Test Mating</b>	Unmated
<b>Water Jetting Test Method</b>	IEC 60529:2001, IP66

# AL5NM-PSA

---

## Packaging and Weights

**Weight, net** 133.89 g | 0.295 lb

## Regulatory Compliance/Certifications

Agency	Classification
CHINA-ROHS	Below maximum concentration value
ISO 9001:2015	Designed, manufactured and/or distributed under this quality management system
REACH-SVHC	Compliant as per SVHC revision on <a href="http://www.andrew.com/ProductCompliance">www.andrew.com/ProductCompliance</a>
ROHS	Compliant
UK-ROHS	Compliant/Exempted



## \* Footnotes

**Insertion Loss Coefficient, typical** 0.05√freq (GHz) (not applicable for elliptical waveguide)

**Immersion Depth** Immersion at specified depth for 24 hours