

TA-NRNF



Type N Male to Type N Female Right Angle Low-PIM Adapter

Product Classification

Product Type Adapter

General Specifications

Body Style Right angle

Inner Contact Plating Silver

Interface N Male

Interface 2 N Female

Mounting Angle Right angle

Outer Contact Plating Trimetal

Pressurizable No

Dimensions

Width 32.38 mm | 1.275 in

Length 36.59 mm | 1.441 in

Diameter 20.25 mm | 0.797 in

Outline Drawing

TA-NRNF

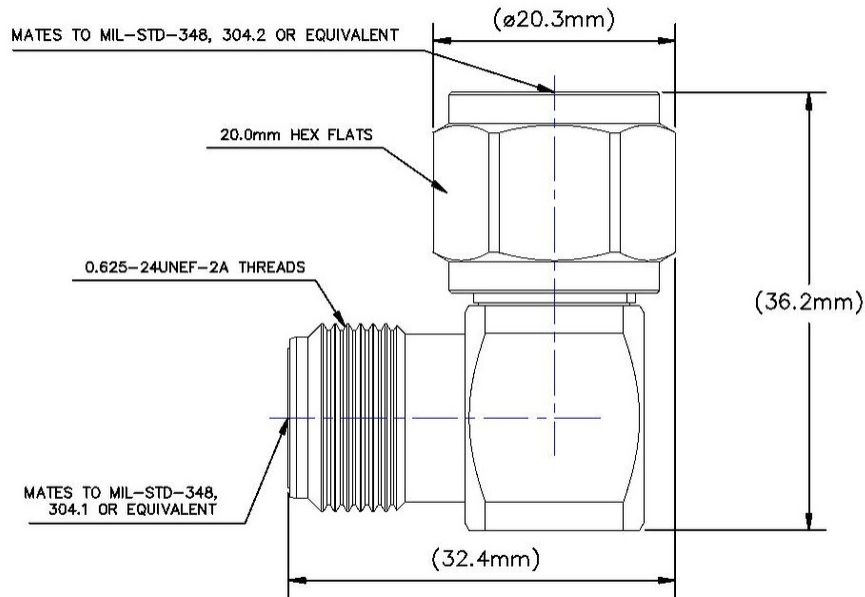

Electrical Specifications

3rd Order IMD at Frequency	-163 -dBc @ 1800 MHz
3rd Order IMD Test Method	Two +43 dBm carriers
Average Power at Frequency	600.0 W @ 900 MHz
Connector Impedance	50 ohm
dc Test Voltage	2500 V
Inner Contact Resistance, maximum	1 mOhm
Insulation Resistance, minimum	5000 MOhm
Operating Frequency Band	0 – 8000 MHz
Outer Contact Resistance, maximum	0.25 mOhm
Peak Power, maximum	10 kW
RF Operating Voltage, maximum (vrms)	707 V

VSWR/Return Loss

Frequency Band	VSWR	Return Loss (dB)
0-3000 MHz	1.065	30.04
3000-6000 MHz	1.222	20.01

TA-NRNF

Mechanical Specifications

Coupling Nut Proof Torque	1.7 N-m 15.046 in lb
Coupling Nut Proof Torque Method	IEC 61169-16:9.3.6
Coupling Nut Retention Force	450 N 101.164 lbf
Coupling Nut Retention Force Method	IEC 61169-16:9.3.11
Insertion Force	28 N 6.295 lbf
Insertion Force Method	IEC 61169-16:9.3.5
Interface Durability	500 cycles
Interface Durability Method	IEC 61169-16:9.5
Mechanical Shock Test Method	IEC 60068-2-27

Environmental Specifications

Operating Temperature	-55 °C to +85 °C (-67 °F to +185 °F)
Storage Temperature	-65 °C to +125 °C (-85 °F to +257 °F)
Attenuation, Ambient Temperature	20 °C 68 °F
Average Power, Ambient Temperature	40 °C 104 °F
Average Power, Inner Conductor Temperature	100 °C 212 °F
Climatic Sequence Test Method	IEC 60068-1
Corrosion Test Method	IEC 60068-2-11
Damp Heat Steady State Test Method	IEC 60068-2-3
Immersion Depth	1 m
Immersion Test Mating	Mated
Immersion Test Method	IEC 60529:2001, IP68
Thermal Shock Test Method	IEC 60068-2-14
Vibration Test Method	IEC 60068-2-6

Packaging and Weights

Weight, net	67.55 g 0.149 lb
--------------------	--------------------

Regulatory Compliance/Certifications

Agency	Classification
CHINA-ROHS	Below maximum concentration value
ISO 9001:2015	Designed, manufactured and/or distributed under this quality management system

TA-NRNF

REACH-SVHC	Compliant as per SVHC revision on www.andrew.com/ProductCompliance
ROHS	Compliant
UK-ROHS	Compliant



* Footnotes

Immersion Depth	Immersion at specified depth for 24 hours
------------------------	-------------------------------------------