

CW-M2-96

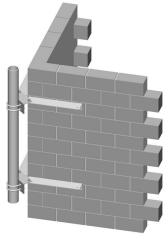

Corner Wall Mount, 2-3/8 in OD x 96 in pipe

Product Classification

Product Type Wall mount kit

General Specifications

Mounting Walls

Pipe, quantity 1

Dimensions

Height 609.6 mm | 24 in

Width 1,219.2 mm | 48 in

Length 2,438.4 mm | 96 in

Pipe Length 2,438.4 mm | 96 in

Pipe Outer Diameter 60.96 mm | 2.4 in

CW-M2-96

Outline Drawing

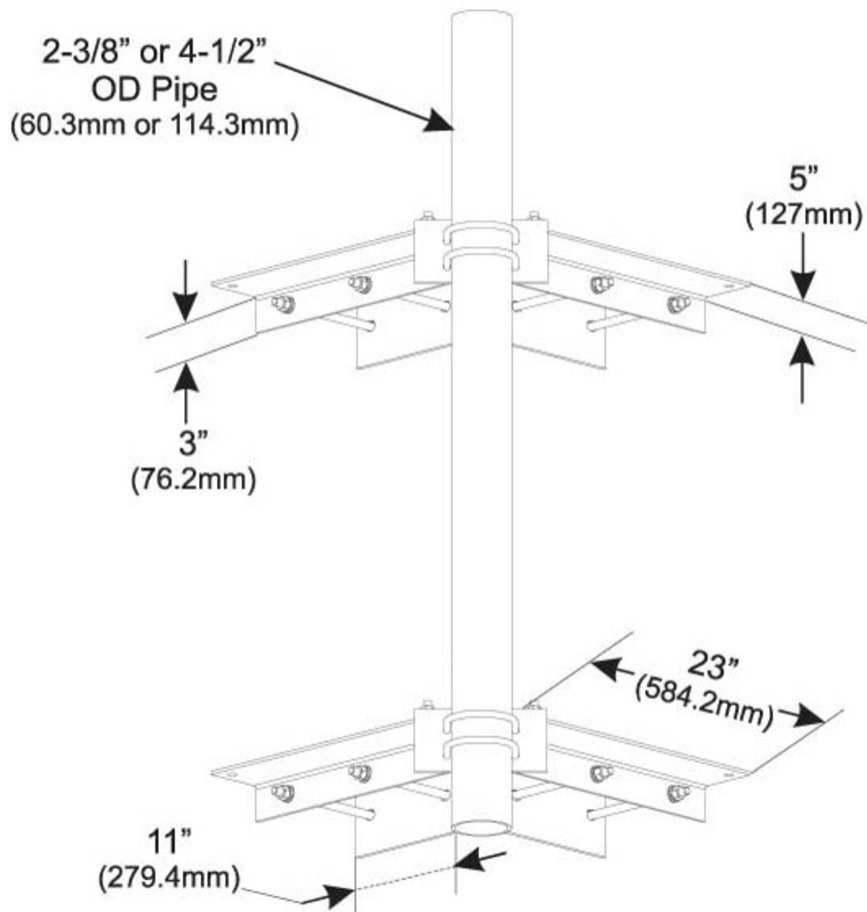

Material Specifications

Material Type Hot dip galvanized steel

Mechanical Specifications

Wind Rating For Specifications, please contact your local ANDREW representative

Packaging and Weights

Included Brackets (2) | Pipe mounts | Wall mount hardware

Packaging quantity 1

Weight, net 60.6 kg | 133.6 lb

CW-M2-96

Regulatory Compliance/Certifications

Agency

ISO 9001:2015

Classification

Designed, manufactured and/or distributed under this quality management system

Included Products

MT-651-96 – Plain End Pipe, 2-3/8 in OD x 96 in .120" A500C
46Ksi

* Footnotes

Wind Rating

BWS—Base Wind Speed; FBC—Florida Building Code