

- 1.0 GENERAL NOTES
 - 1.1 ALL METRIC DIMENSIONS ARE IN BRACKETS [X.X]
 - 1.2 FEATURES CRITICAL TO QUALITY ARE INDICATED IN ROUNDED BOX (X.X)
- 2.0 DESIGN NOTES
- 3.0 MANUFACTURING/SPECIAL REQUIREMENTS
 - 3.1 TIGHTEN ALL BOLTS SECURING FLAT PLATES BY THE TURN-OF-NUT METHOD.
- 4.0 TEST
- 5.0 PACKAGING
 - 5.1 PACKAGING MUST BE AGREED TO IN WRITING BY COMMSCOPE PRIOR TO MASS-PRODUCTION APPROVAL.
 - 5.2 PARTS ARE TO BE PACKAGING IN A MANNER OT PREVENT DAMAGE DURING SHIPMENT & STORAGE.
 - 5.3 PACKAGING TO ADHERE TO ALL COMMSCOPE, LOCAL & FOREIGN (WHERE APPLICABLE) SHIPPING REQUIREMENTS.
 - 5.4 PACKAGING & PARTS TO BE FREE OF ALL CONTAMINANTS INCLUDING PAPER FROM BOX, DIRT, DUST, OILS, MOLD RELEASE, DETERGENT AND ALL OTHER FOREIGN MATERIALS.

| REVISIONS | | | |
|-----------|------------------|-------------------|-----------------------|
| REV. | DESCRIPTION | DATE | APPROVED |
| A | INITIAL RELEASE | JL1183 19DEC22 | JW1064 40157351CMO |
| B | REDESIGNED MODEL | YMENG 23MAY23 | JX1030 40171556CMO |

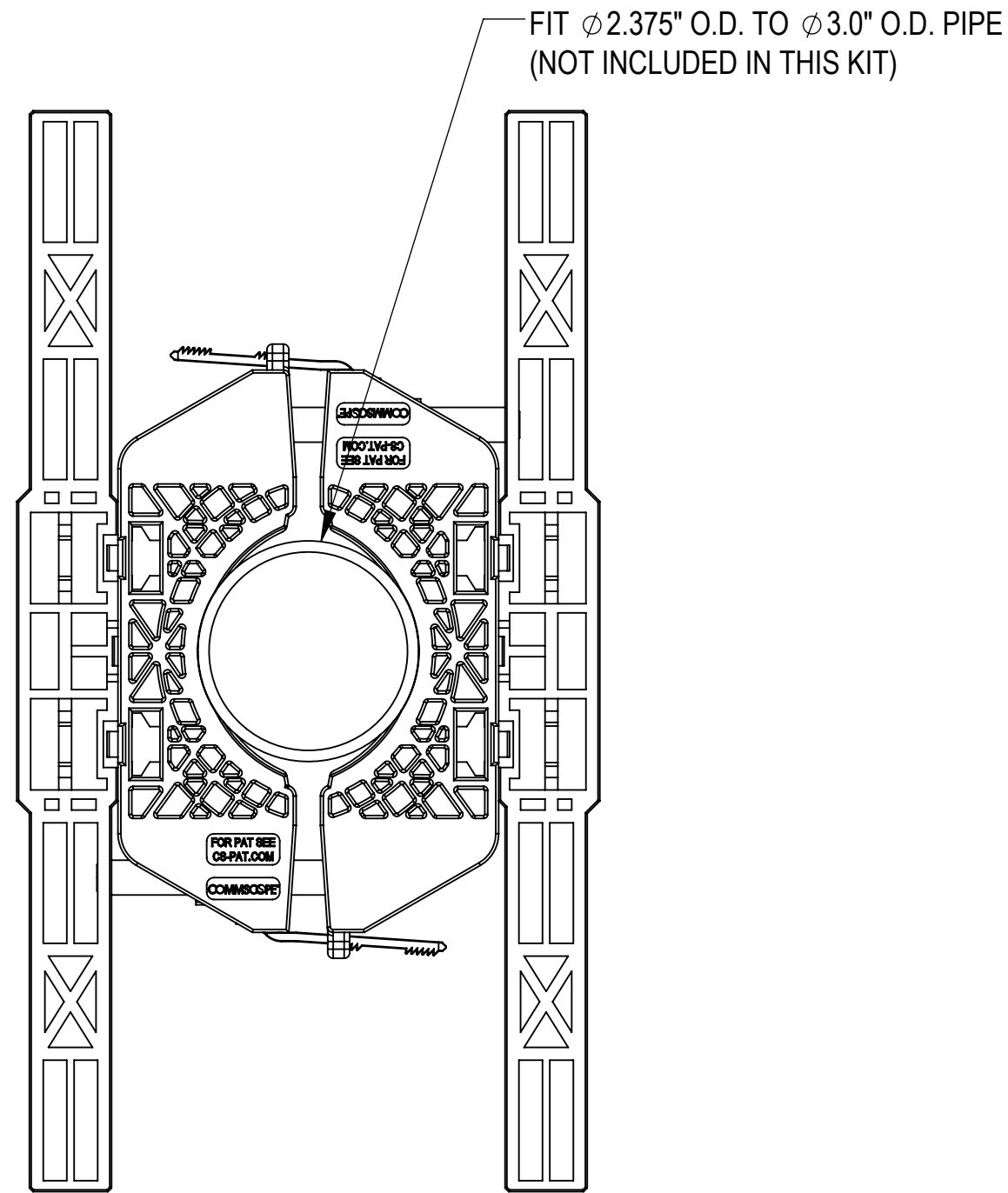

ASSEMBLY TOP VIEW

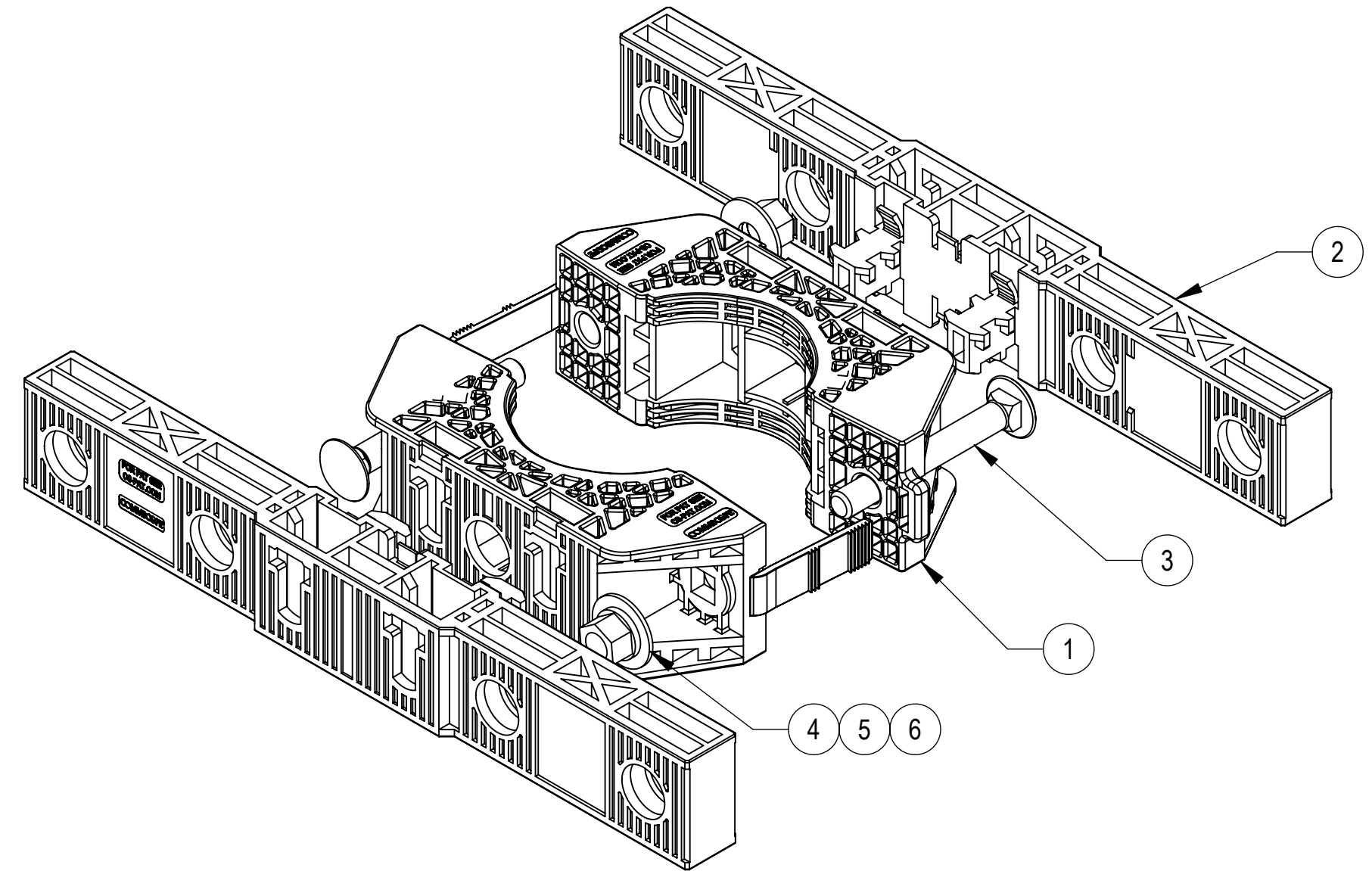

INSTALLATION ASSEMBLY

COMPONENT PART NUMBERS PROVIDED FOR ASSEMBLY PURPOSES;
INDIVIDUAL COMPONENTS MAY BE SHIPPED AS PARTS WITHIN AN INCLUDED KIT.

| ITEM NO. | PART NUMBER | DESCRIPTION | QTY. |
|----------|-------------|-------------------------------------|------|
| 1 | PGCS-1000 | CLAMP, FRONT-REAR, POLYMER 4CP | 2 |
| 2 | PGCS-3000 | PANEL, POLYMER, 8CP | 2 |
| 3 | 9615-15 | BOLT, CARRIAGE, 3/8-16, 3, STL GALV | 2 |
| 4 | GWF-03 | 3/8" FLAT WASHER | 2 |
| 5 | GWL-03 | 3/8" GALV LOCK WASHER | 2 |
| 6 | GN-03 | 3/8" GALV HEX NUT | 2 |

| | | |
|--------------|--------|---------------------|
| DENSITY | | lbs/in ³ |
| MASS | 1.40 | lbs |
| VOLUME | 33.26 | in ³ |
| SURFACE AREA | 560.94 | in ² |
| HEIGHT | 6.5" | |
| LENGTH | 12.0" | |
| WIDTH | 2.0" | |

| COMMSCOPE, INC. OF NORTH CAROLINA | | | | | | | | | |
|---|-------------|------------------------------|----------------------------------|--------------|---------------------|---------|--------|----------|--------|
| TOLERANCES | | | | | SAP MATERIAL MASTER | | | | |
| 1 PLACE .X[X] ± 0.2[6.3] | | 3 PLACE .XXX[X] ± 0.060[1.5] | | | PGP-CS12 | | | | |
| 2 PLACE .XX[X] ± 0.12[3.0] | | ANGLES ± 2° | | | | | | | |
| FINISH | | | | | MATERIAL | | | | |
| UNLESS OTHERWISE SPECIFIED DIMENSIONS ARE IN INCHES INTERPRET PER ANSI Y 14.5M-1994 | | | | | | | | | |
| | NAME | DATE | TITLE | | | | | | |
| CE | JL1183 | 19DEC22 | PG PREMIUM, CBL-SUPPORT, 12-HOLE | | | | | | |
| RW | YMENG | 06/13/2023 | | | | | | | |
| AD | JX1030 | 06/18/2023 | | | | | | | |
| RE | YMENG | 06/19/2023 | | | | | | | |
| ECN | 40171556CMO | | SCALE | DOCUMENT NO. | | | | | |
| | | | 1:5 | PGP-CS12 | | | | | |
| SIZE | Auth Group | INSL | MODEL | | | DRAWING | | | |
| C | | | VERSION | STATUS | REVISION | VERSION | STATUS | REVISION | SHEET |
| | | | 01 | RE | B | 01 | RE | B | 1 OF 1 |