

4

3

2

1

- 1.0 GENERAL NOTES
- 1.1 ALL METRIC DIMENSIONS ARE IN BRACKETS [X.X]
- 1.2 FOR PATENT INFO: <https://www.cs-pat.com>



- 2.0 DESIGN NOTES
- 2.1 ANY HAZARDS OR OBSTRUCTIONS TO THE CLIMBING FACILITY AND SAFETY CLIMB MUST BE IDENTIFIED PRIOR TO INSTALLING THE APPURTENANCE. ADDITIONAL PRODUCTS MAY BE REQUIRED TO MAINTAIN THE INTEGRITY OF THE SAFETY CLIMB. DURING INSTALLATION, TEMPORARY AND/OR PERMANENT PRECAUTIONARY MEASURES SHOULD BE TAKEN TO PRESERVE THE CLIMBING FACILITY AND/OR SAFETY CLIMB.
- 2.2 UP TO 5.0° TAPER AVAILABLE ON MODELS THAT SUPPORT ADJUSTMENT

- 3.0 MANUFACTURING/SPECIAL REQUIREMENTS
- 3.1 TIGHTEN ALL BOLTS SECURING FLAT PLATES BY THE TURN-OF-NUT METHOD. TIGHTEN ALL U-BOLTS USING TURN-OF-NUT METHOD WITH ATTENTION TO LEAVE EQUAL DISTANCE AND EQUAL FORCE ON EACH LEG OF THE U-BOLT.

- 4.0 TEST
- 5.0 PACKAGING
- 5.1 PACKAGING SHALL MEET COMMSCOPE REQUIREMENTS PER DOCUMENT IS-PL-3005.
- 5.2 PRINTED DOCUMENT TO BE PLACED INSIDE POLYBAG AND THEN IN SHIPPING CONTAINER.
- 5.3 EXTRA HARDWARE MAYBE SUPPLIED, BAGGED AND SHIPPED.

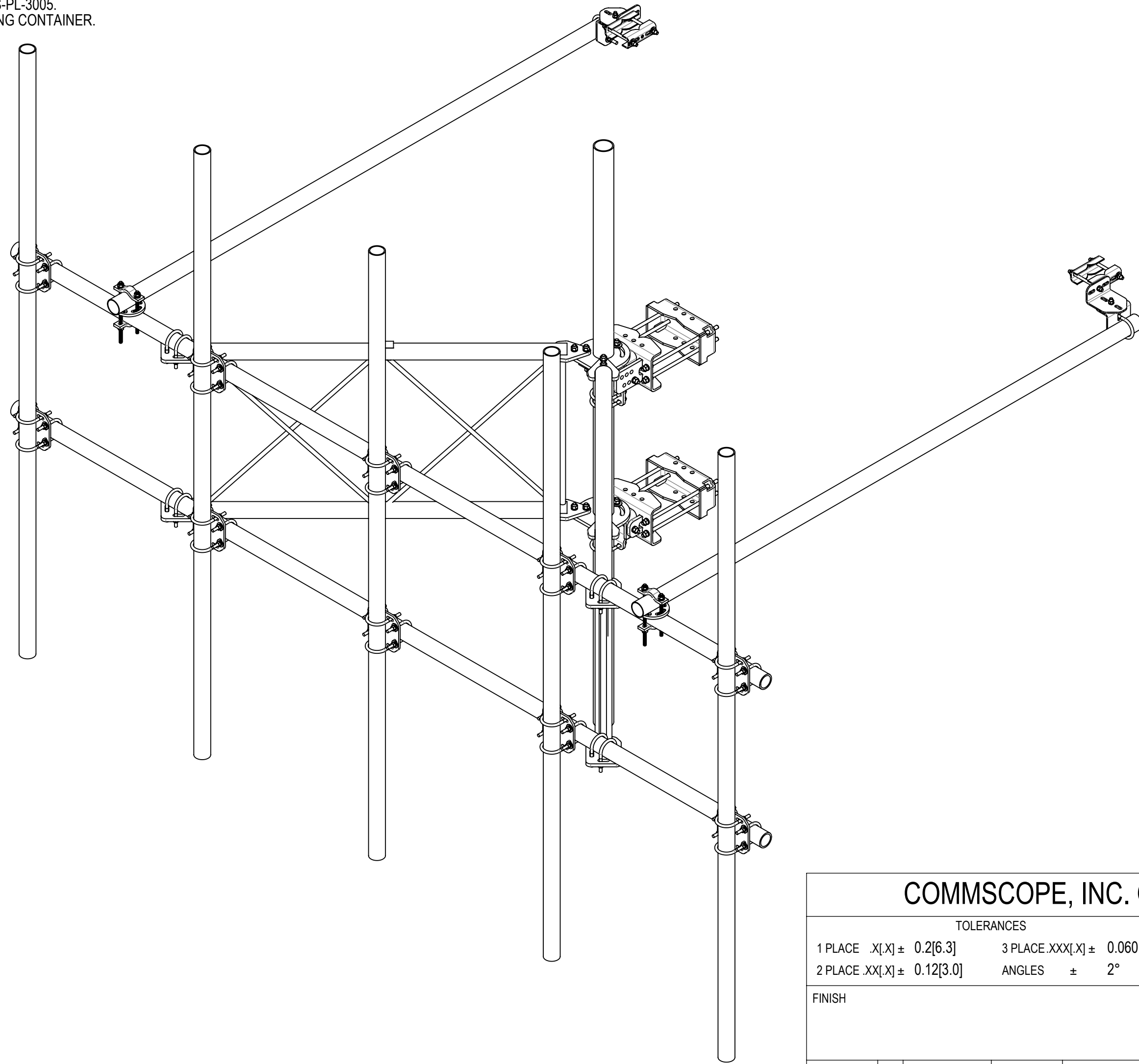
REVISIONS			
REV.	DESCRIPTION	DATE	APPROVED
A	INITIAL RELEASE	YMENG 08OCT23	YW1047 40179448CMO



COMMSCOPE, INC. OF NORTH CAROLINA								
TOLERANCES		SAP MATERIAL MASTER						
1 PLACE .X[X] ± 0.2[6.3]	3 PLACE .XXX[X] ± 0.060[1.5]	SFG23RHDXL15-5-126						
2 PLACE .XX[X] ± 0.12[3.0]	ANGLES ± 2°							
FINISH		MATERIAL						
UNLESS OTHERWISE SPECIFIED DIMENSIONS ARE IN INCHES INTERPRET PER ANSI Y 14.5M-1994	NAME	DATE	SF, 15',(5)2.88"X126"-PIPES-PIM-SPACED					
	CE YMENG	08OCT23						
	RW YMENG	10/18/2023						
	AD YW1047	10/18/2023						
	RE YMENG	10/18/2023						
ECN 40179448CMO	SCALE		DOCUMENT NO.					
	1:32		SFG23RHDXL15-5-126					
SIZE	Auth Group	INSL	MODEL					
C	 	VERSION	STATUS	REVISION	VERSION	STATUS	REVISION	SHEET 1 OF 5
		00	RE	A	00	RE	A	

DENSITY		lbs/in ³
MASS	1188.63	lbs
VOLUME	4191.37	in ³
SURFACE AREA	36280.84	in ²
HEIGHT	126"	
LENGTH	180"	
WIDTH	120"	

4

3

2

1

4

3

2

1

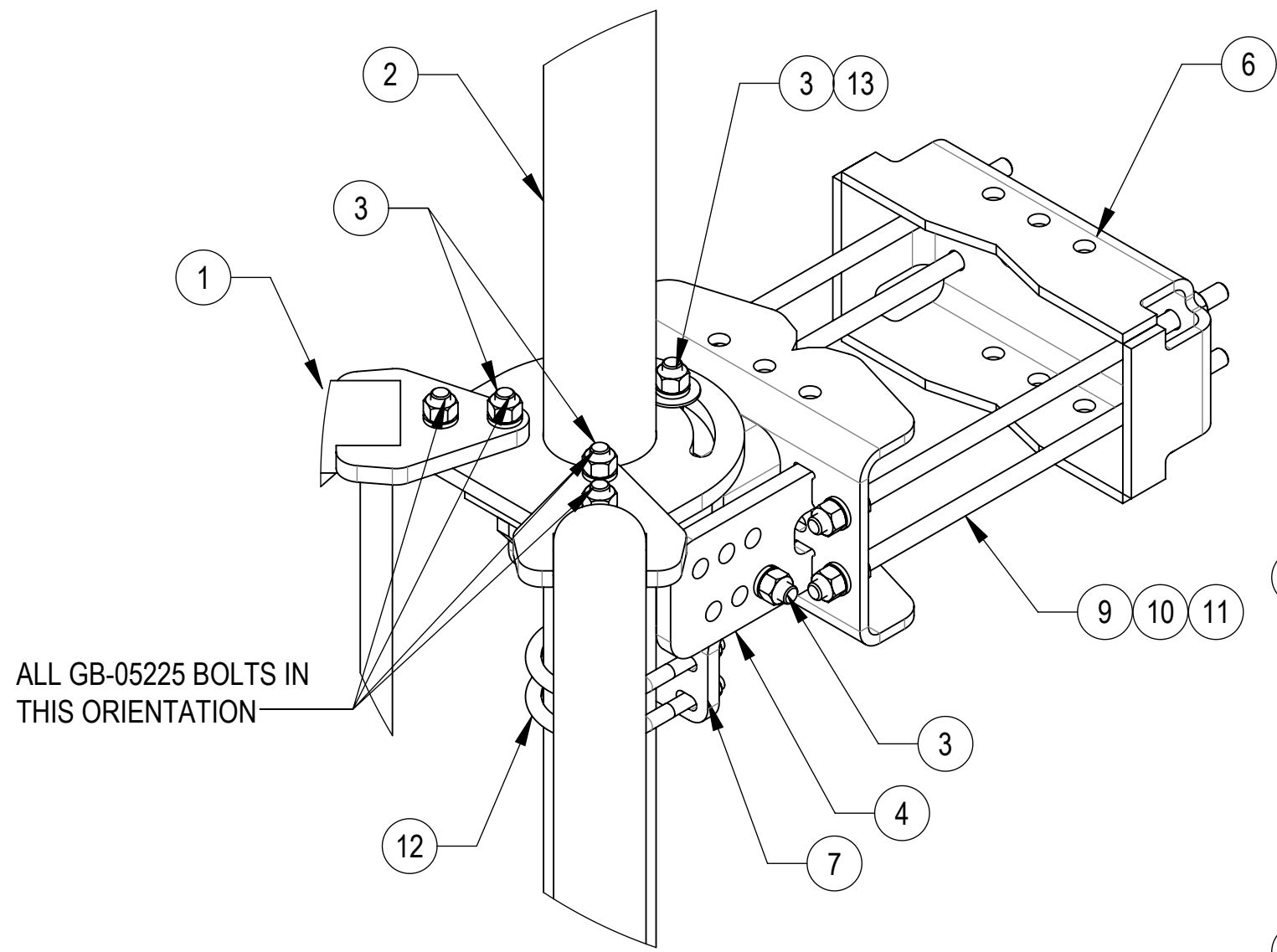

ALL GB-05225 BOLTS IN THIS ORIENTATION

DETAIL A
SCALE 1 : 5

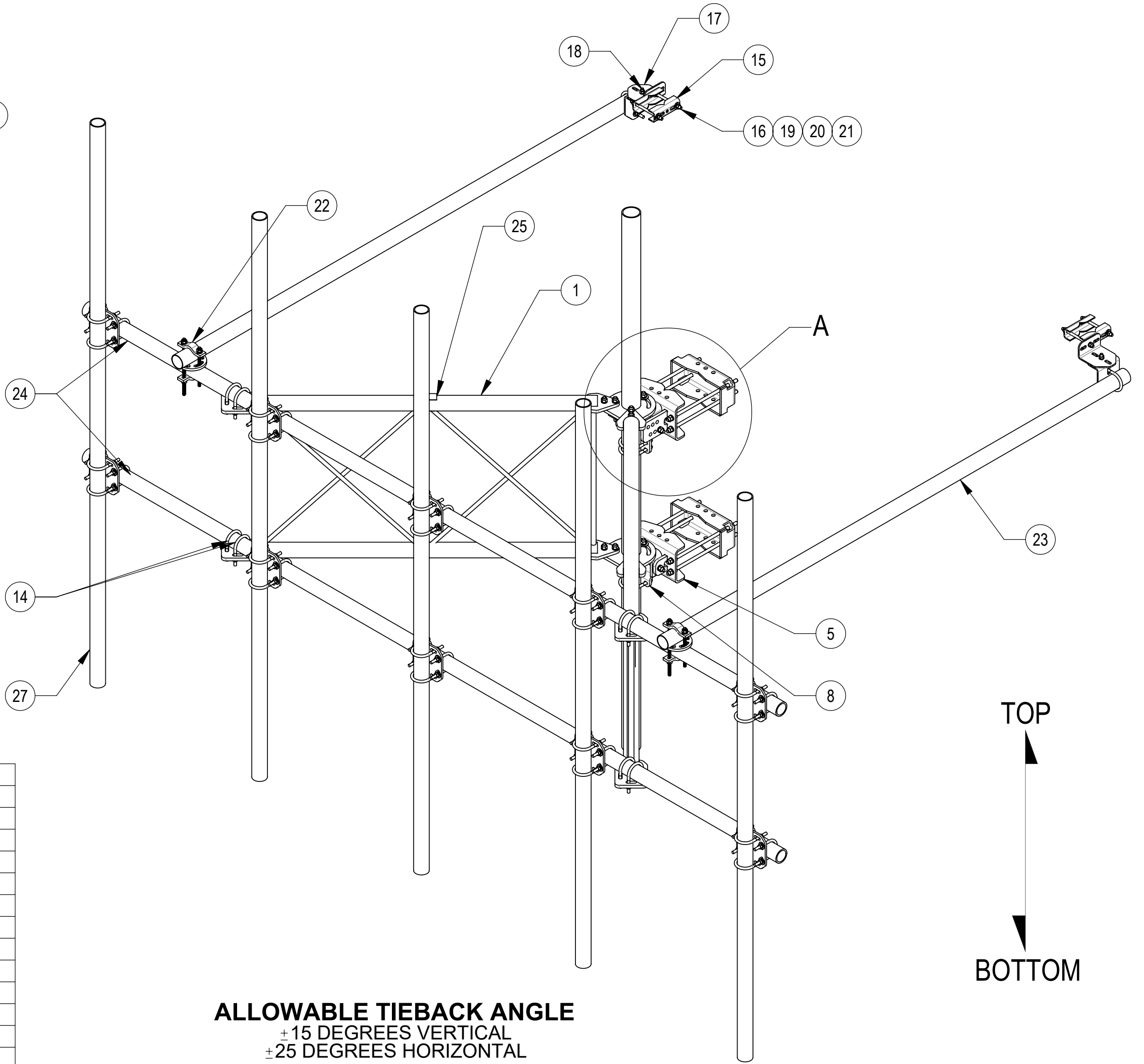

ALLOWABLE TIEBACK ANGLE
+ 15 DEGREES VERTICAL
± 25 DEGREES HORIZONTAL

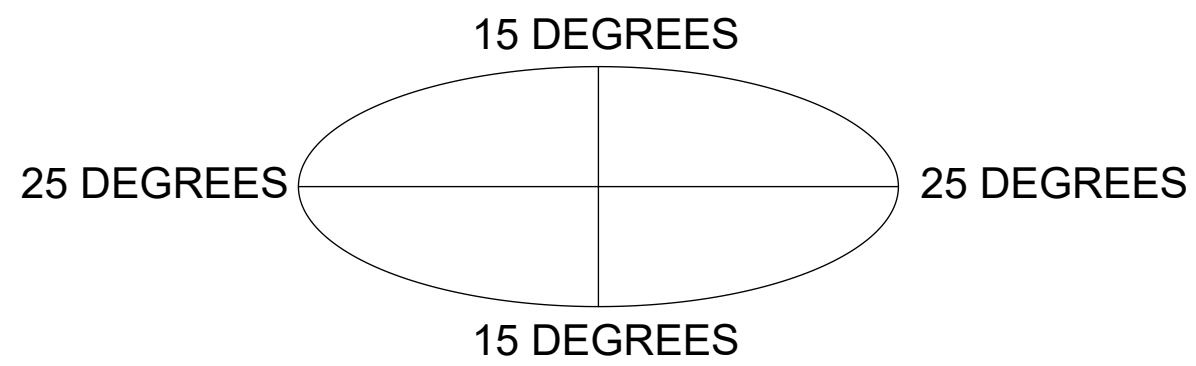

COMPONENT PART NUMBERS PROVIDED FOR ASSEMBLY PURPOSES;
INDIVIDUAL COMPONENTS MAY BE SHIPPED AS PARTS WITHIN AN INCLUDED KIT.

ITEM	PART NO.	DESCRIPTION	QTY.	WEIGHT	NOTE NO.
1	SFG23180-00	ARM, STANDOFF, SFG23	2	120.07 LBS	
2	SFG2204	WELDMENT, BACK VERTICAL ARM MOUNT	1	97.29 LBS	
3	GB-05225	5/8" X 2-1/4" GALV BOLT KIT	14	0.28 LBS	
4	SFG2380	WELDMENT, HD, TOP TAPER BRACKET	1	22.78 LBS	
5	SFG2381	WELDMENT, HD, LOWER TOWER LEG BRACKET	1	17.42 LBS	
6	SFG2289	G2 RRU BACK CLAMP, HD	2	18.65 LBS	
7	SFG2386	WELDMENT, SFG2 AZIMUTH BRACKET	1	10.69 LBS	
8	SFG2397-00	WELDMENT, G23 AZIMUTH BRACKET	1	8.56 LBS	
9	MT-382-18	5/8" X 18" THREADED ROD	8	1.43 LBS	
10	GWL-05	5/8" GALV LOCK WASHER	16	0.03 LBS	
11	GN-05	5/8" GALV HEX NUT	24	0.08 LBS	
12	GUB-4355	1/2" X 3-5/8" X 5" GALV U-BOLT	3	0.71 LBS	
13	GWF-05	5/8" GALV FLAT WASHER, 1.7OD	2	0.06 LBS	
14	GUB-4352	1/2" X 3" X 5-1/4" GALV U-BOLT	10	0.71 LBS	
15	SAB01	FORMED CLAMP	4	1.35 LBS	
16	MT-379-8	1/2" X 8" GALV THREADED ROD	4	0.45 LBS	
17	XAU01	ANGLE, CROSSOVER, 1.9-3.5" X 1.9-3.5" OD	4	2.98 LBS	
18	GB-04145	1/2" X 1-1/2" GALV BOLT KIT	2	0.13 LBS	
19	GWF-04	1/2" GALV FLAT WASHER	8	0.04 LBS	
20	GWL-04	1/2" GALV LOCK WASHER	10	0.01 LBS	
21	GN-04	1/2" GALV HEX NUT	10	0.04 LBS	
22	XP-R	CROSSOVER PLATE, ROUND, UP TO 3.5" OD	2	6.20 LBS	
23	MT546120120	PIPE, 2.875"OD X 120"	2	35.44 LBS	
24	MT546180276	PIPE, 2.875"OD X 180"	2	115.33 LBS	
25	SFG23100	LABEL, SFG23RHDXL	1	0.04 LBS	
26	XP-2525	CROSSOVER PLATE KIT, 2-7/8 OD X 2-7/8 OD	10	8.37 LBS	
27	MT-546-126	PIPE, 2.875"OD X 126"	5	61.05 LBS	

COMMSCOPE, INC. OF NORTH CAROLINA

TITLE
SF, 15',(5)2.88"X126"-PIPES-PIM-SPACED

SIZE C	SCALE 1:16	DOCUMENT NO. SFG23RHDXL15-5-126
------------------	----------------------	---

DRAWING	VERSION	STATUS	REVISION	SHEET 2 OF 5
	00	RE	A	

© 2023 CommScope, Inc. Confidential

4

3

2

1

4

3

2

1

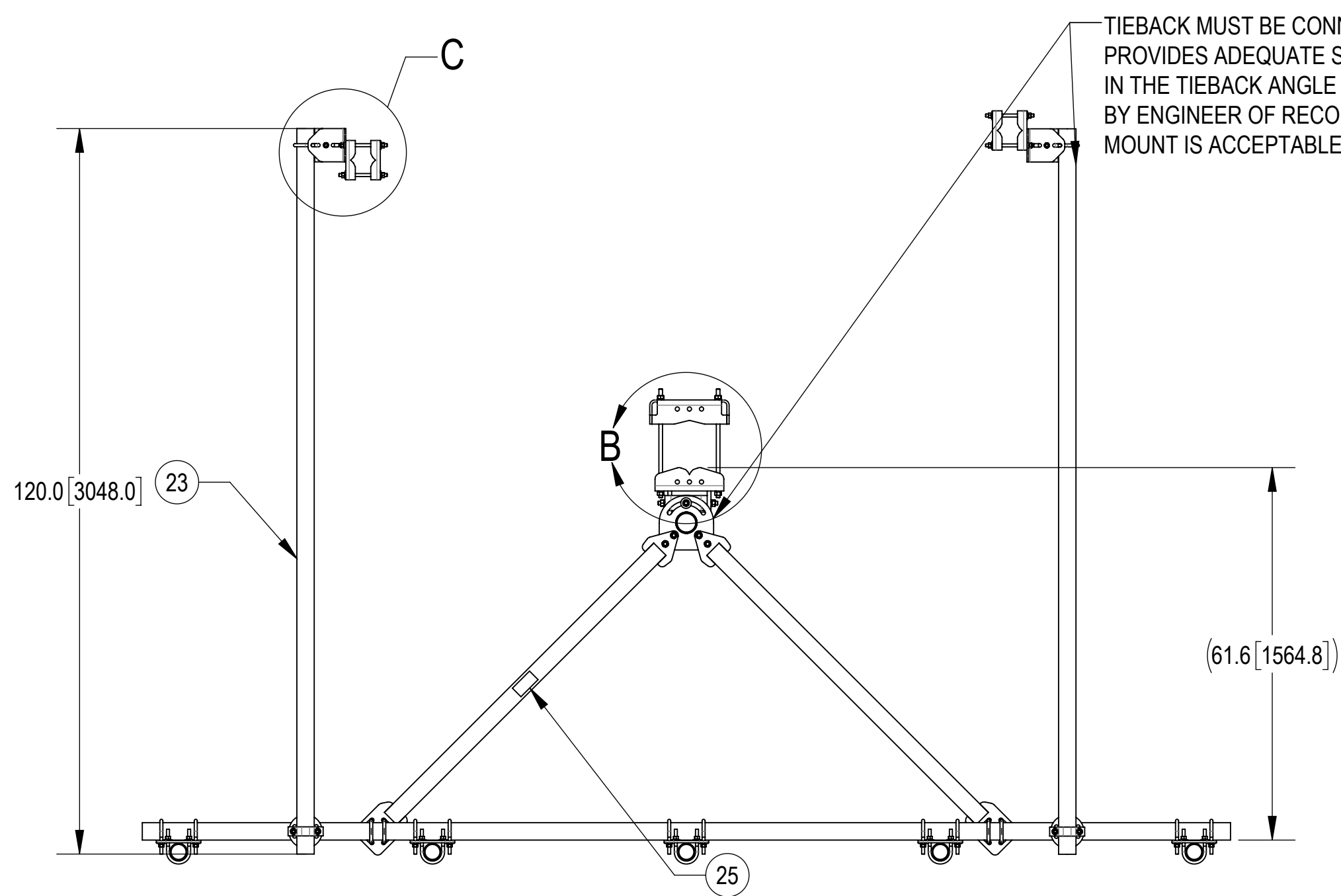

TIEBACK MUST BE CONNECTED TO A RIGID MEMBER THAT PROVIDES ADEQUATE SUPPORT WITHIN THE LIMITS NOTED IN THE TIEBACK ANGLE RANGE DETAIL. UNLESS APPROVED BY ENGINEER OF RECORD. SPINE STEM OF NEIGHBORING MOUNT IS ACCEPTABLE.

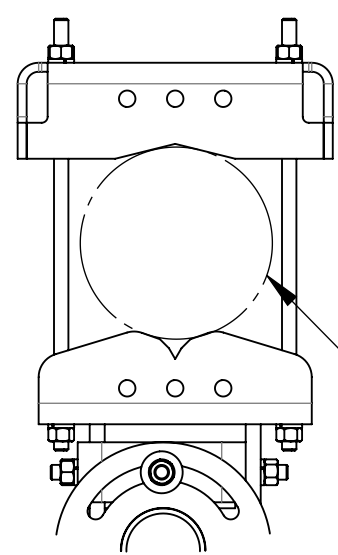

DETAIL B
SCALE 1 : 8

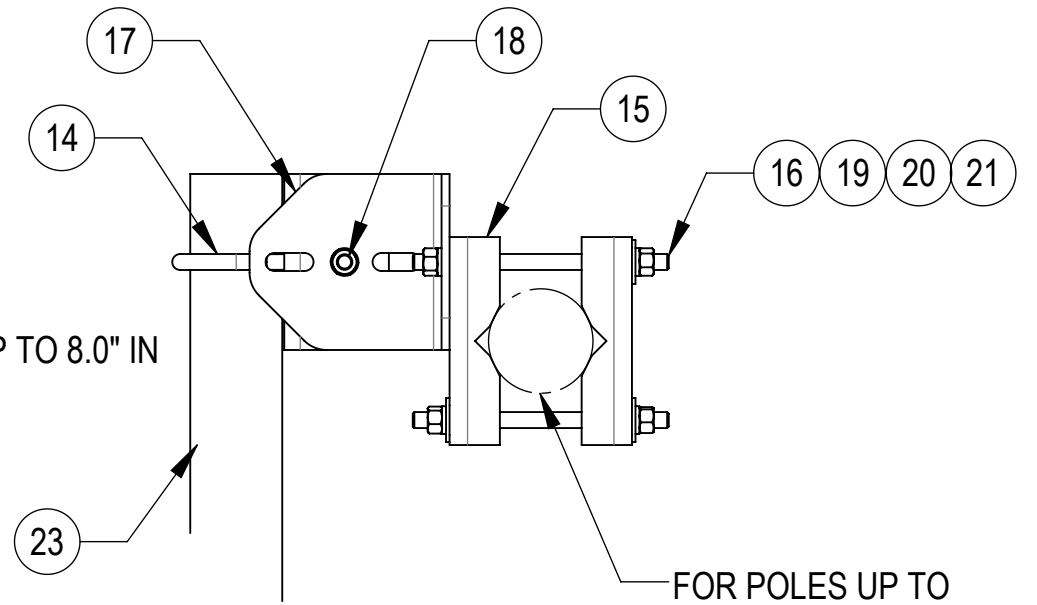

DETAIL C
SCALE 1 : 6

ALLOWABLE TIEBACK ANGLE
±15 DEGREES VERTICAL
±25 DEGREES HORIZONTAL

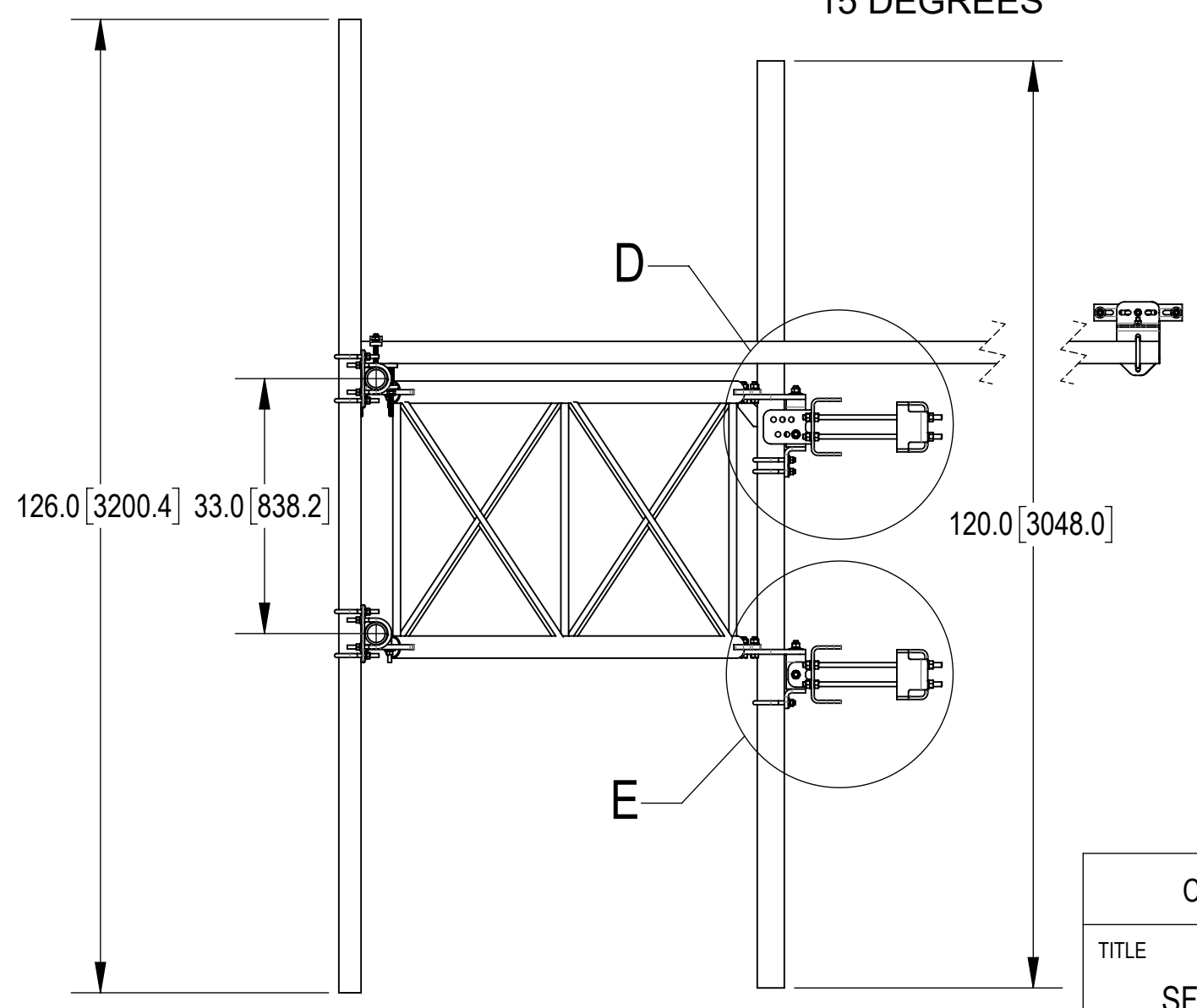
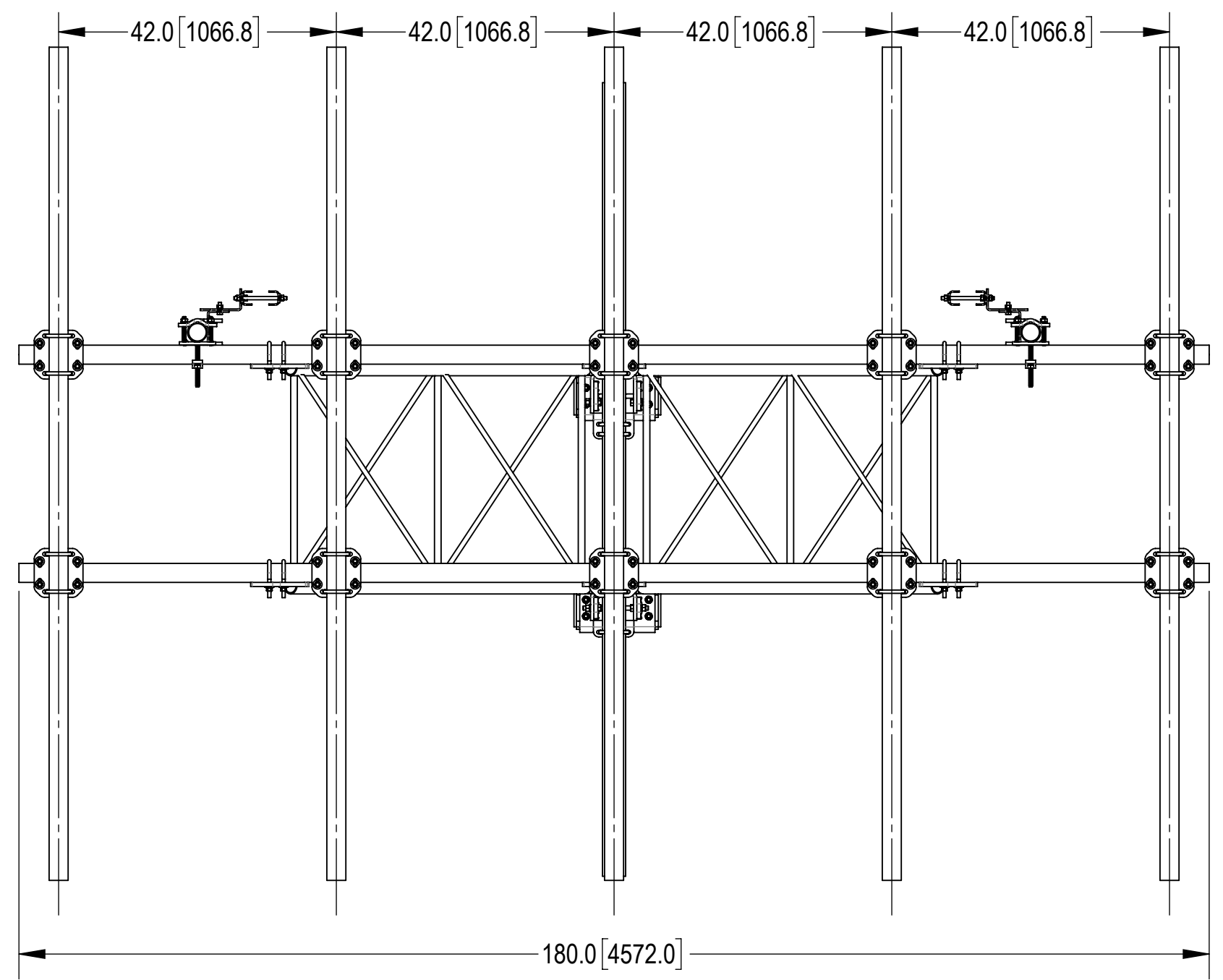
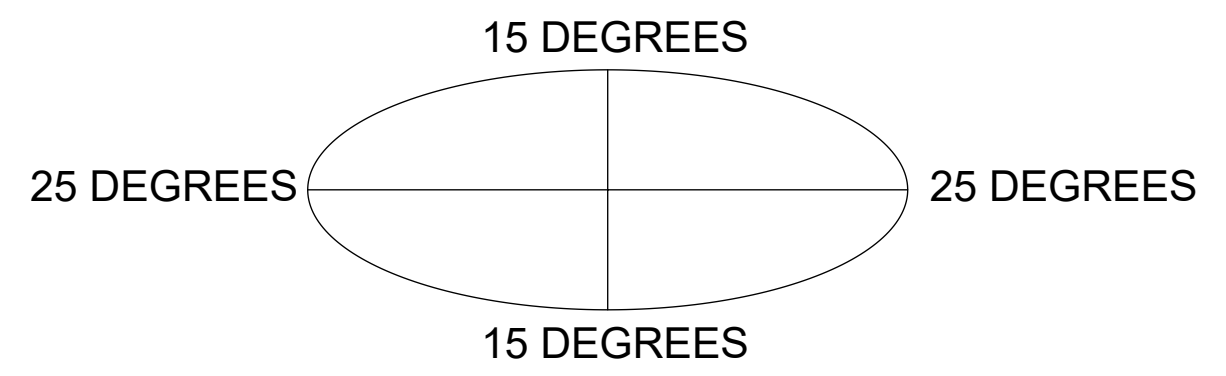

TOP
↓
BOTTOM

COMMSCOPE, INC. OF NORTH CAROLINA				
TITLE SF, 15', (5) 2.88" X 126" - PIPES - PIM - SPACED				
SIZE C	SCALE 1:21	DOCUMENT NO. SFG23RHDXL15-5-126		
DRAWING		VERSION	STATUS	REVISION
		00	RE	A
				SHEET 3 OF 5

4

3

2

1

4

3

2

1

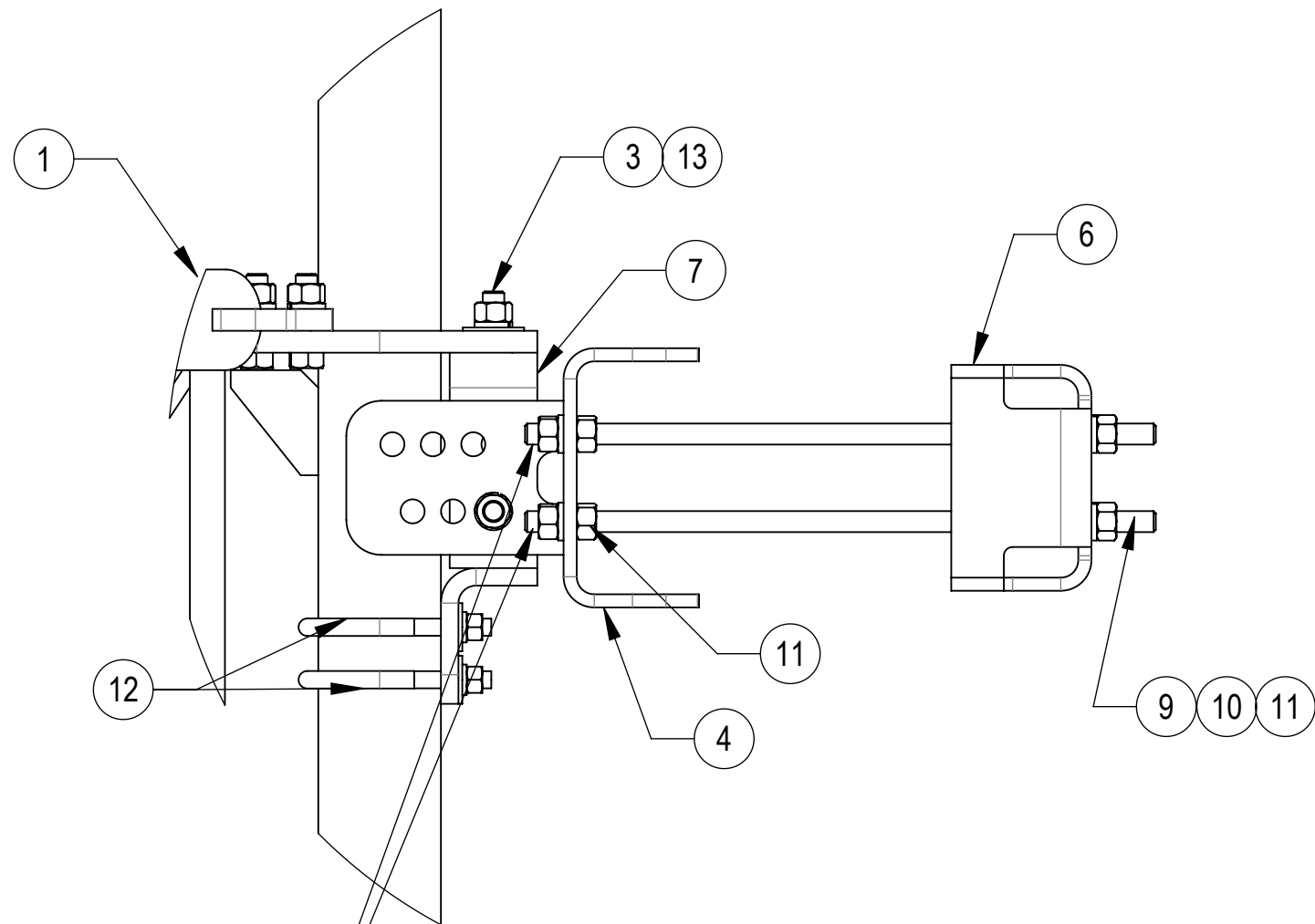

DETAIL D
SCALE 1 : 5

THE THREADED ROD CAN ONLY EXPOSE 4 TO 7 THREADS ON ONE SIDE OF THE BRACKET, WHICH IS TO PREVENT INTERFERENCE WITH THE SIDE BOLTS

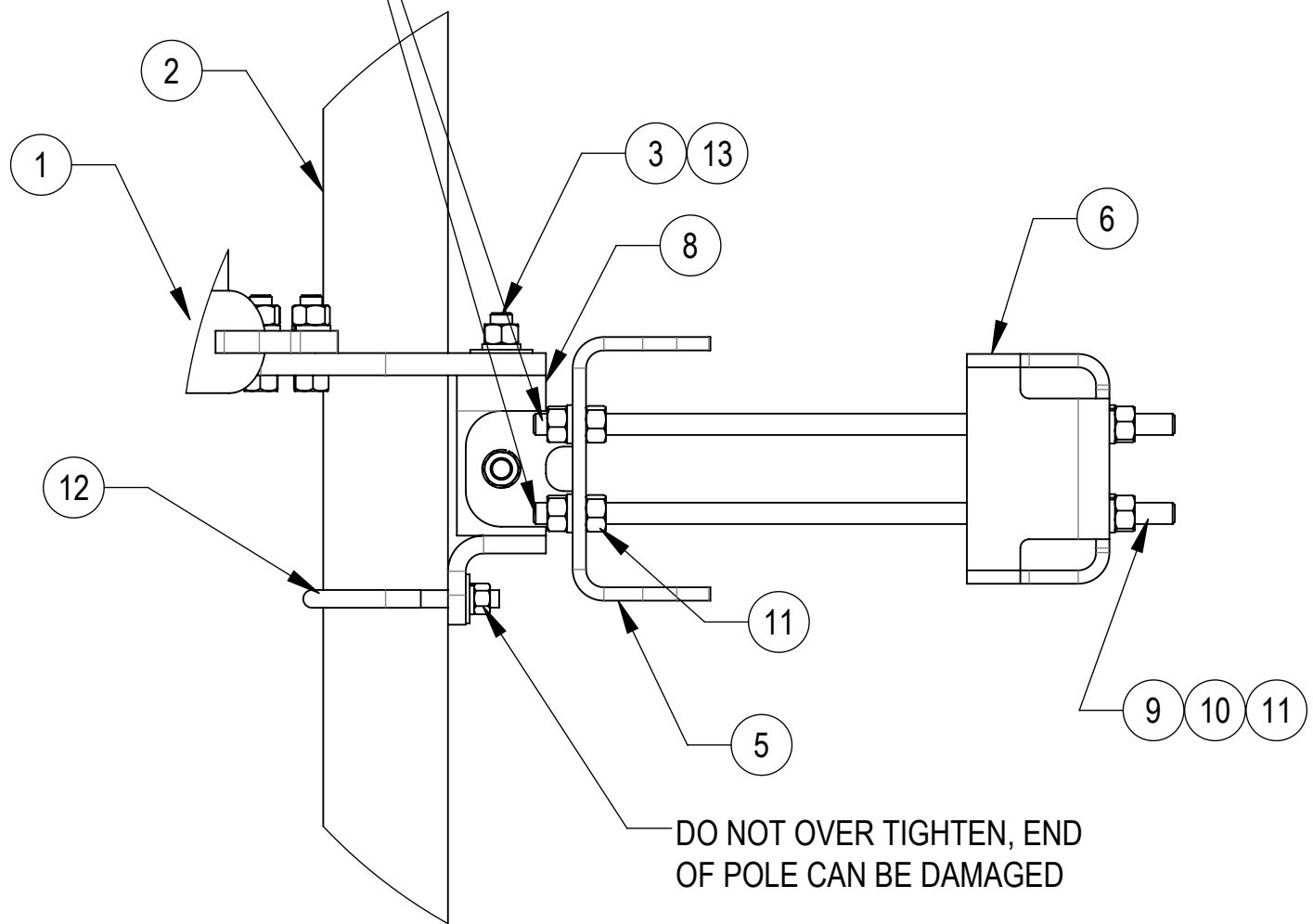

DETAIL E
SCALE 1 : 5

DO NOT OVER TIGHTEN, END OF POLE CAN BE DAMAGED

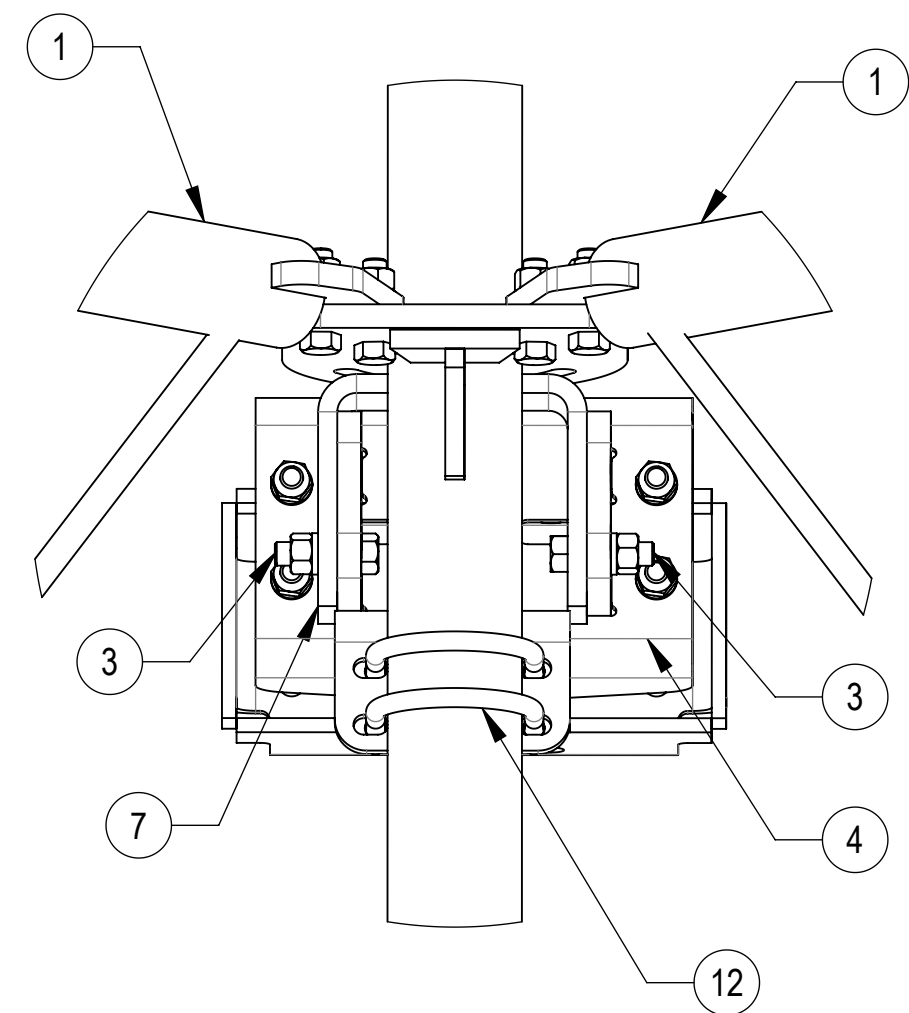

DETAIL ISO TOP ROTATED VIEW
SCALE 1 : 5

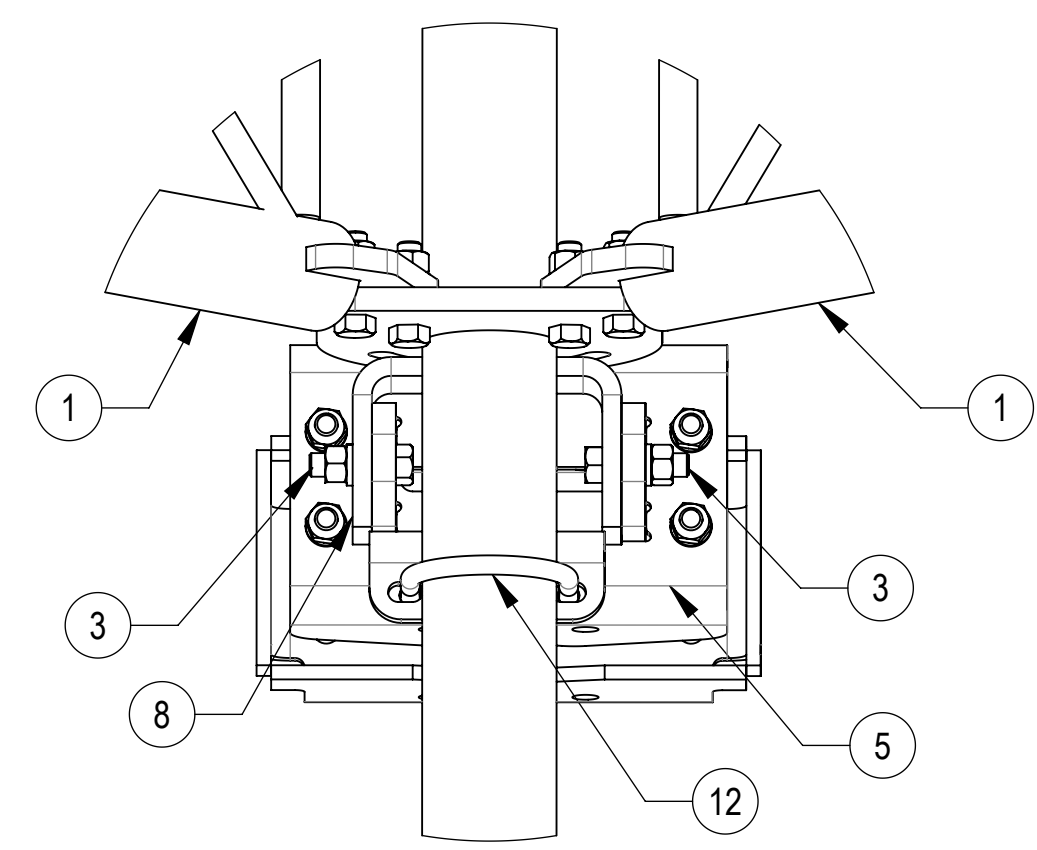

DETAIL ISO BOTTOM ROTATED VIEW
SCALE 1 : 5

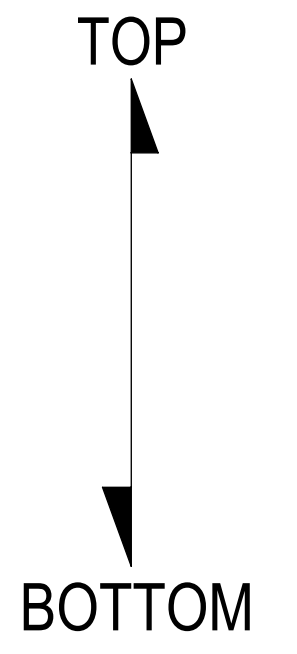

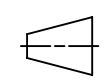
COMMSCOPE, INC. OF NORTH CAROLINA				
TITLE SF,15',(5)2.88"X126"-PIPES-PIM-SPACED				
SIZE C	SCALE 1:21	DOCUMENT NO. SFG23RHDXL15-5-126		
 		DRAWING		SHEET 4 OF 5
		VERSION 00	STATUS RE	

4

3

2

1

4

3

2

1

ACCESSORIES ORDERED SEPARATELY:

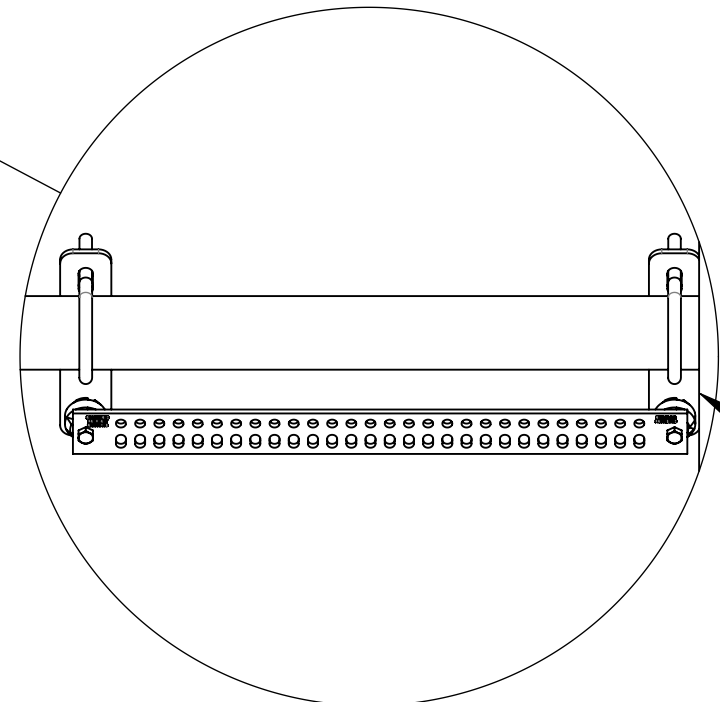
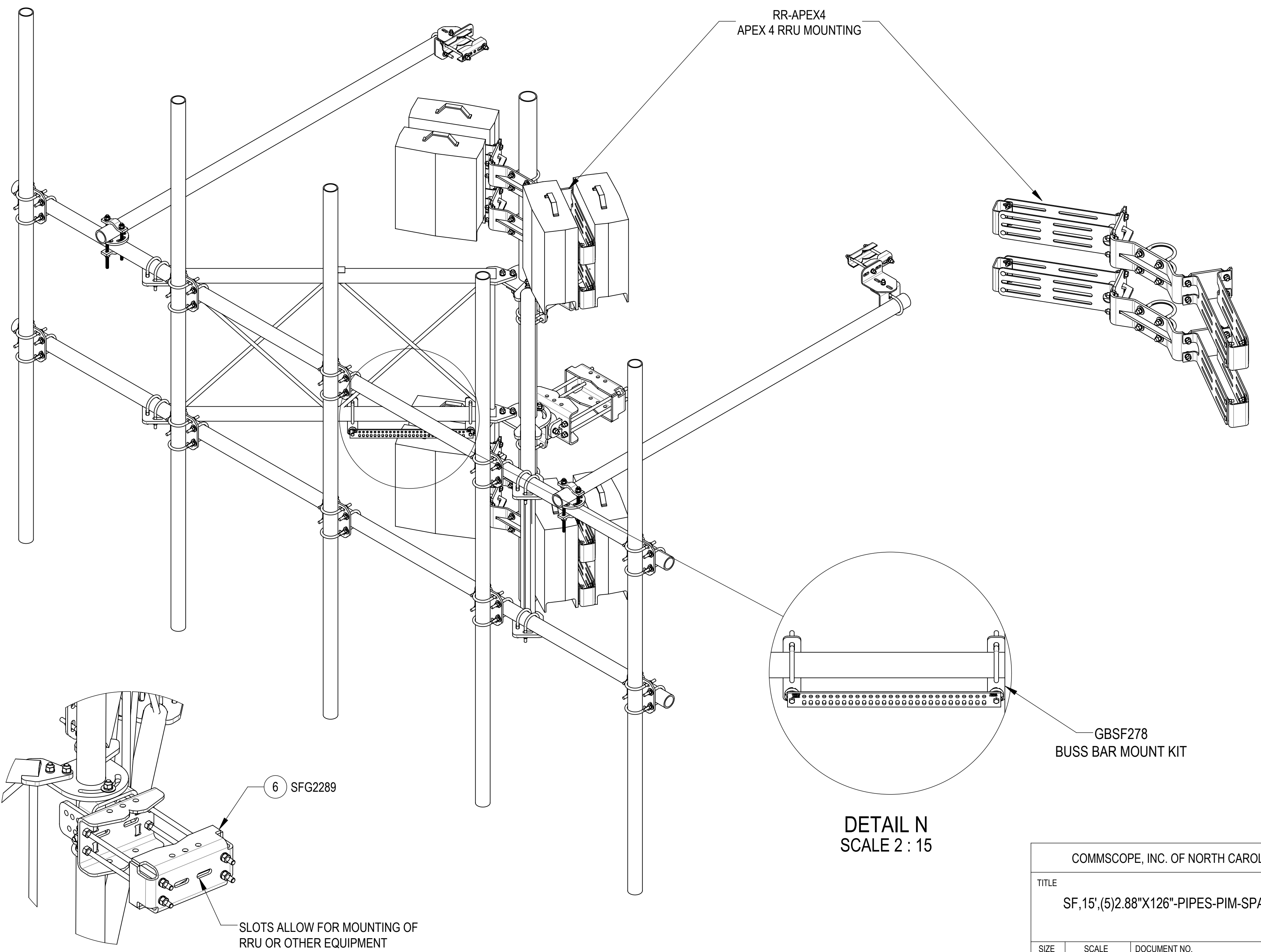

DETAIL N
SCALE 2 : 15

COMMSCOPE, INC. OF NORTH CAROLINA				
TITLE SF,15',(5)2.88"X126"-PIPES-PIM-SPACED				
SIZE C	SCALE 1:12	DOCUMENT NO. SFG23RHDXL15-5-126		
		DRAWING		SHEET
		VERSION	STATUS	REVISION
		00	RE	A
				5 OF 5

4

3

2

1