

- 1.0 GENERAL NOTES
 - 1.1 ALL METRIC DIMENSIONS ARE IN BRACKETS [X. X]
 - 1.2 FOR PATENT INFO: <https://www.cs-pat.com>
- 2.0 DESIGN NOTES
- 3.0 MANUFACTURING/SPECIAL REQUIREMENTS
 - 3.1 TIGHTEN ALL BOLTS SECURING FLAT PLATES BY THE TURN-OF-NUT METHOD. TIGHTEN ALL U-BOLTS USING TURN-OF-NUT METHOD WITH ATTENTION TO LEAVE EQUAL DISTANCE AND EQUAL FORCE ON EACH LEG OF THE U-BOLT.
- 4.0 TEST
- 5.0 PACKAGING
 - 5.1 PACKAGING SHALL MEET COMMSCOPE REQUIREMENTS PER DOCUMENT IS-PL-3005
 - 5.2 PRINTED DOCUMENT TO BE PLACED INSIDE POLYBAG AND THEN IN SHIPPING CONTAINER
 - 5.3 EXTRA HARDWARE MAY BE SUPPLIED, BAGGED AND SHIPPED

REV.	DESCRIPTION	DATE	APPROVED
A	INITIAL RELEASE	MSM 18FEB11	TP
B	UPDATE WEIGHTS	MSM 05APR12	TP
C	UPDATED DRAWING FORMAT; ADDED NOTES; ADDED DIMENSIONS 126[3200.4]&122[3105.7]	LL1090 23FEB24	BCROSS 40189629CMO

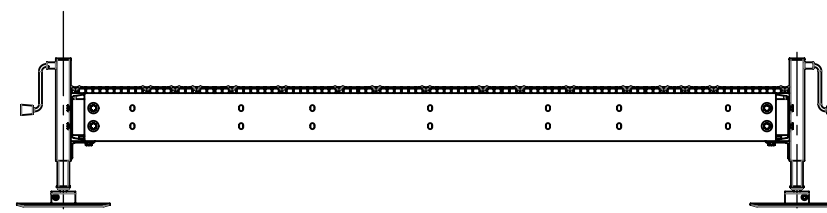
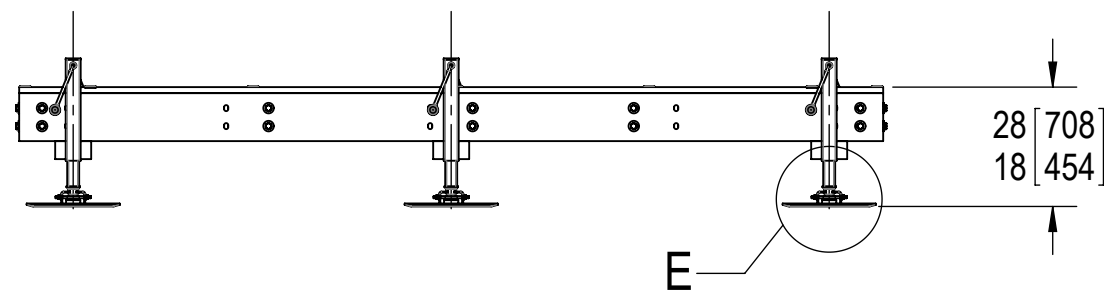
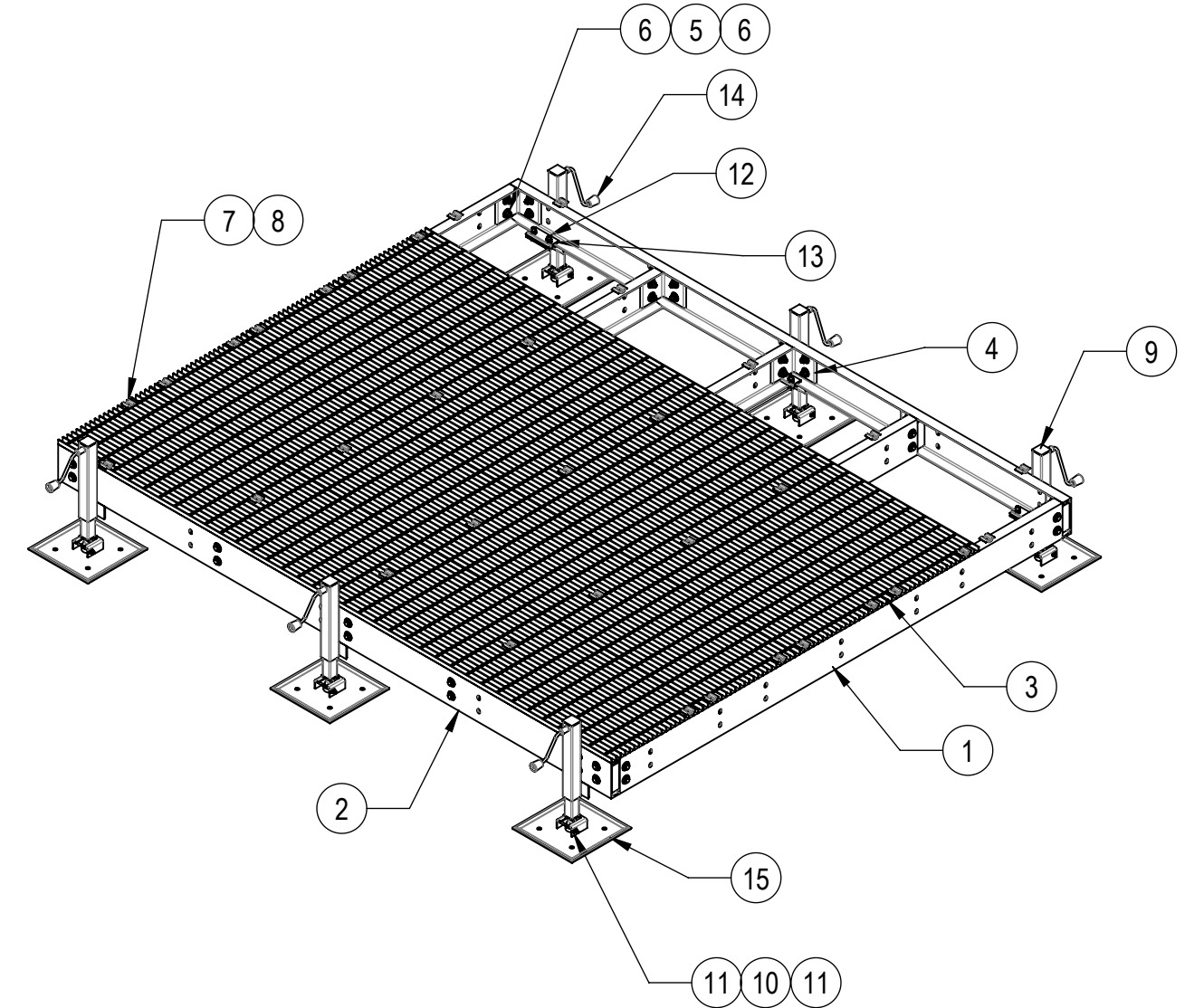
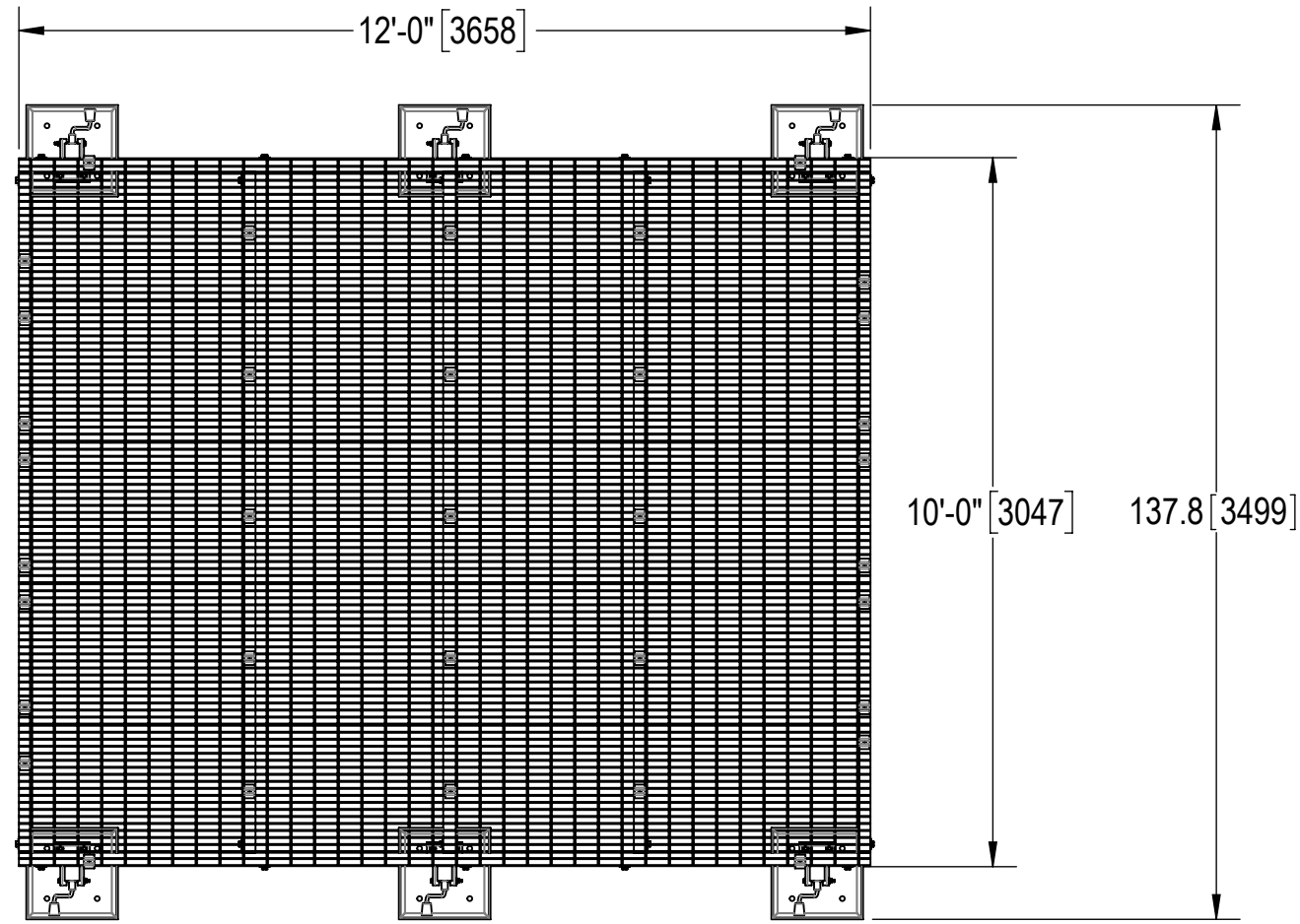

COMPONENT PART NUMBERS PROVIDED FOR ASSEMBLY PURPOSES;
INDIVIDUAL COMPONENTS MAY BE SHIPPED AS PARTS WITHIN AN INCLUDED KIT.

HIDE BAR GRATING FOR CLARITY

ITEM	PART NO.	DESCRIPTION	QTY.	WEIGHT	NOTE NO.
1	MTC7902101002	10' CENTER CHANNEL	5	108.98 LBS	
2	MTC790271201	12' SIDE CHANNEL	2	136.26 LBS	
3	MTC790271203	24" X 144" BAR GRATING	5	172.46 LBS	
4	MTC790203	CHANNEL ADAPTER ANGLE	10	7.07 LBS	
5	GB-05205	5/8" X 2" GALV BOLT KIT	40	0.26 LBS	
6	GWF-05	5/8" GALV FLAT WASHER, 1.7OD	80	0.06 LBS	
7	MTC390324	BAR GRATING CLIP	35	0.17 LBS	
8	TS1220	12-24 X 2" SELF DRILLING SCREW	35	0.03 LBS	
9	MTC7902AL05	ADJUSTABLE LEG SUB ASSEMBLY	6	17.16 LBS	
10	GB-03505	3/8" X 5" GALV BOLT KIT	6	0.17 LBS	
11	GWF-03	3/8" GALV FLAT WASHER	12	0.01 LBS	
12	GB-0522A	5/8" X 2-1/4" GALV BOLT KIT (A325)	12	0.28 LBS	
13	MTC7902AL07	PINCH PLATE	6	1.60 LBS	
14	EQPALC	CRANK	6	1.33 LBS	
15	MTC7902AL04	PIVOTING FOOT FOR ADJUSTABLE LEG	6	21.30 LBS	

COMMSCOPE, INC. OF NORTH CAROLINA									
TOLERANCES			SAP MATERIAL MASTER						
1 PLACE .X[X] ± 0.12[3.0]		3 PLACE .XXX[X] ± 0.03[0.8]		EQ-P1012-AL					
2 PLACE .XX[X] ± 0.06[1.5]		ANGLES ± 2°							
FINISH			MATERIAL						
UNLESS OTHERWISE SPECIFIED DIMENSIONS ARE IN INCHES INTERPRET PER ANSI Y 14.5M-1994	NAME	DATE	TITLE						
	CE MSM	18FEB11	EQUIPMENT PLATFORM 10' X 12' W/ 6 AL						
	RW LL1090	03/01/2024							
	AD YMENG	03/01/2024	SCALE	DOCUMENT NO.					
	RE YMENG	03/01/2024	1:32	EQ-P1012-AL					
ECN 40189629CMO									
SIZE	Auth Group	INSL	MODEL		DRAWING				
C	⊕	◁	VERSION	STATUS	REVISION	VERSION	STATUS	REVISION	SHEET
			01	RE	C	01	RE	C	1 OF 2

DENSITY		lbs/in ³
MASS	2112.55	lbs
VOLUME	7213.01	in ³
SURFACE AREA	71465.07	in ²
HEIGHT	28.0"	
LENGTH	144.0"	
WIDTH	137.8"	

4

3

2

1

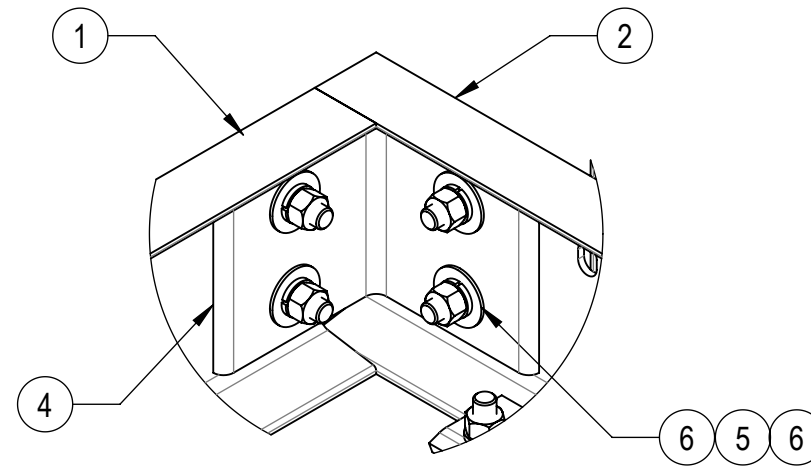
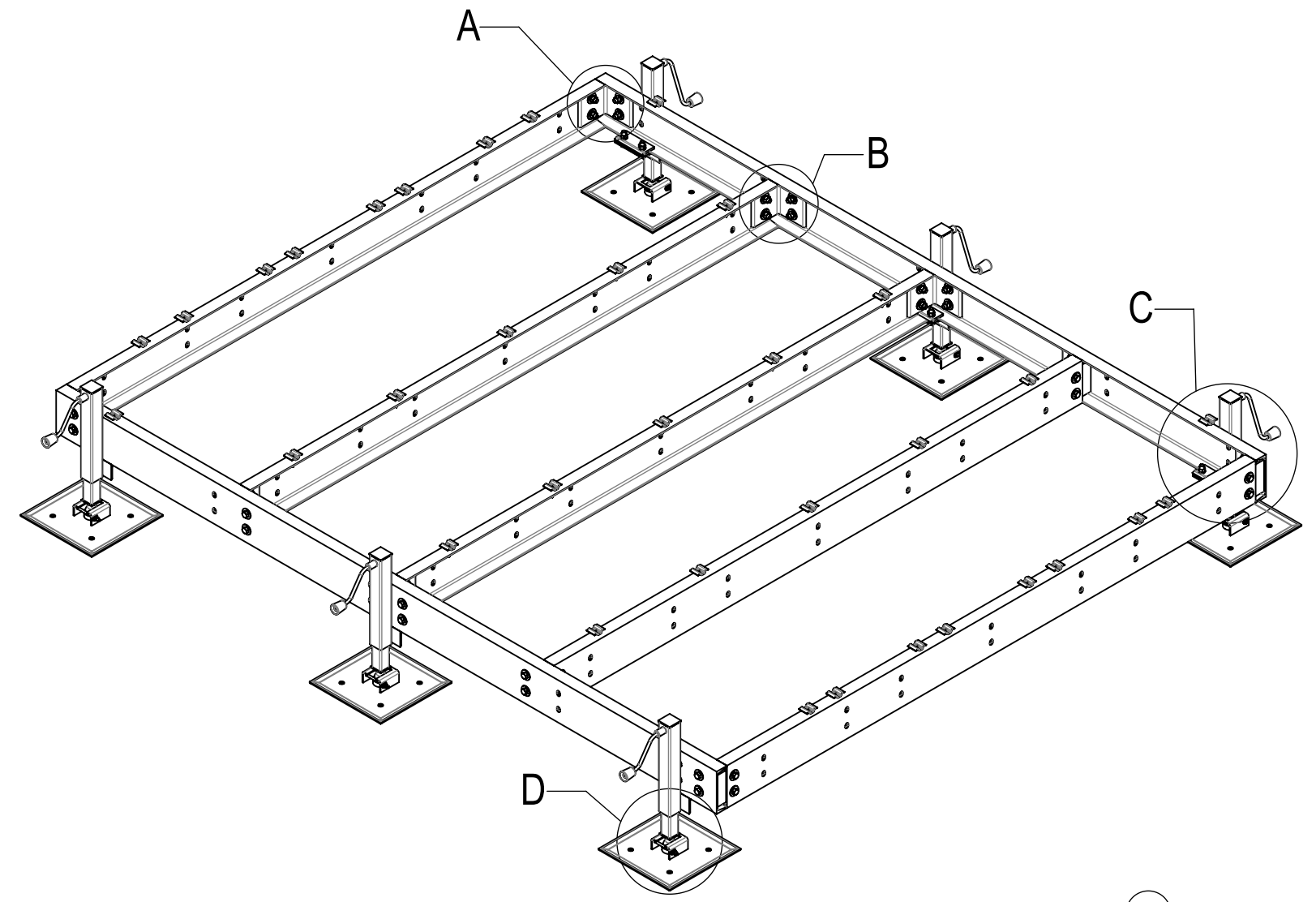
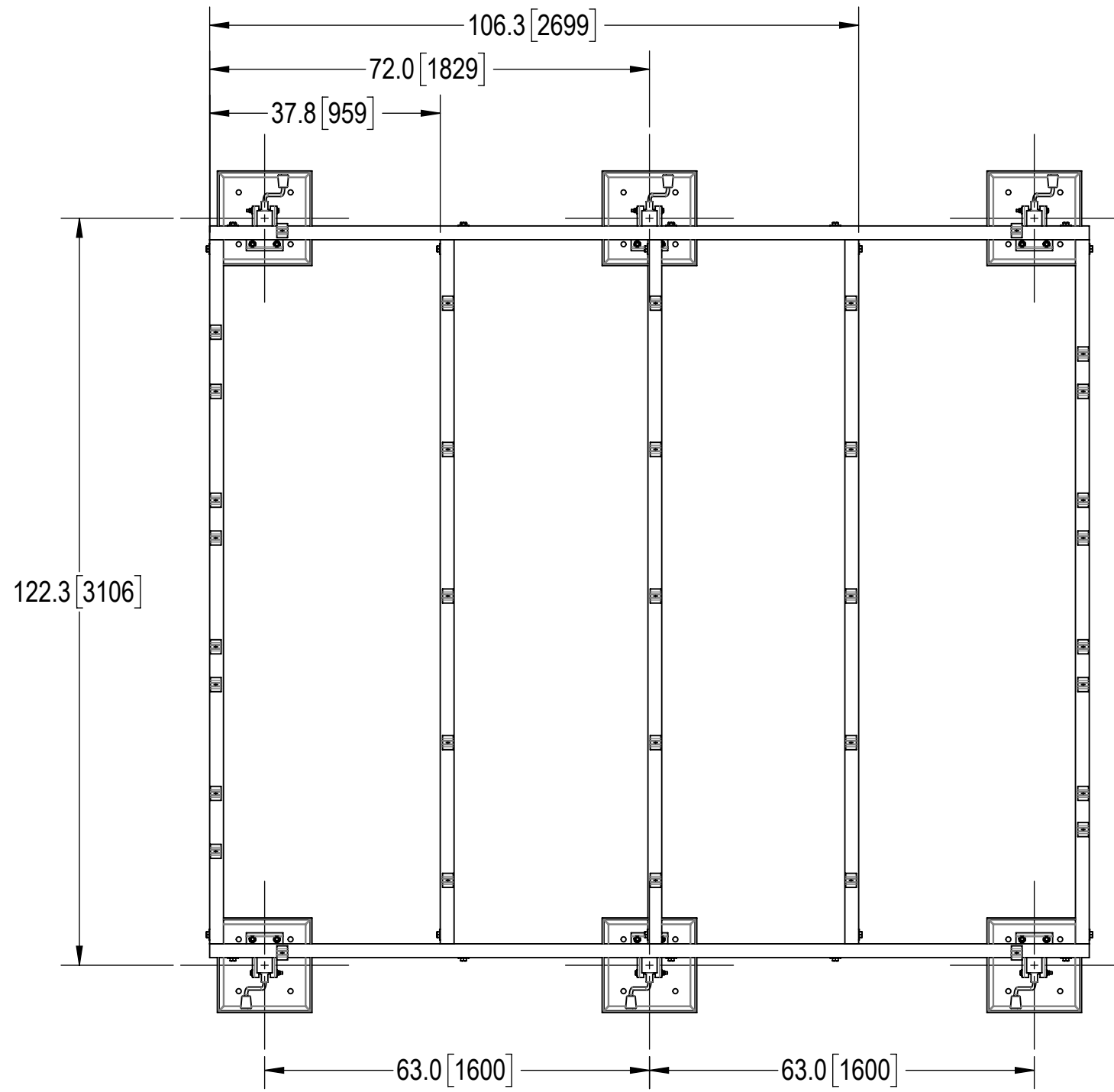

DETAIL A
SCALE 1 : 5

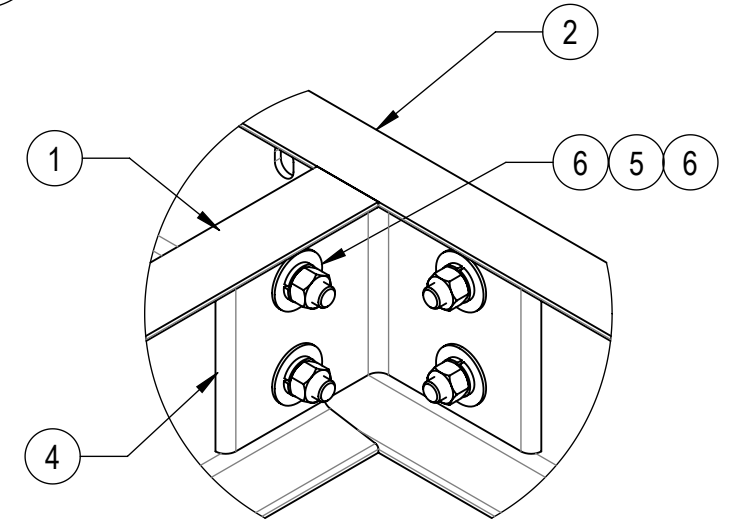

DETAIL B
SCALE 1 : 5

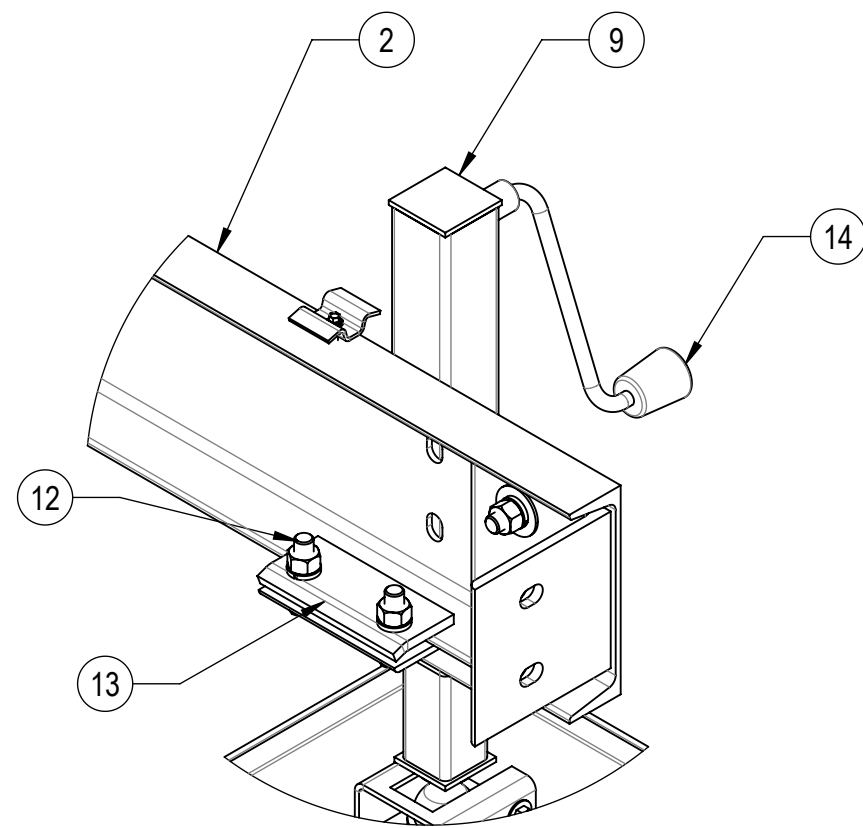

DETAIL C
SCALE 1 : 6

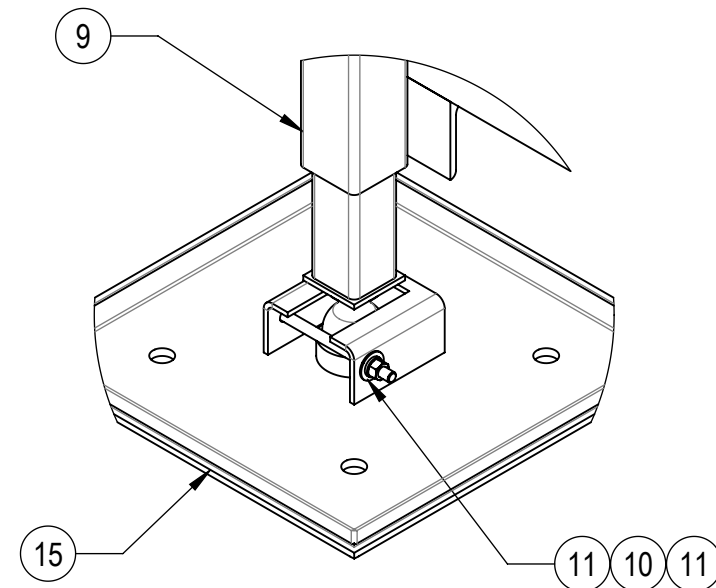

DETAIL D
SCALE 1 : 6

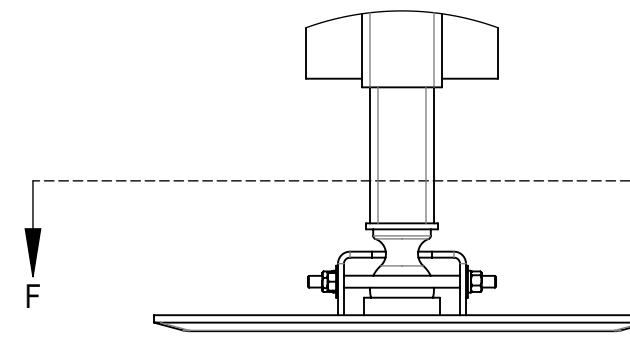

DETAIL E
SCALE 1 : 6

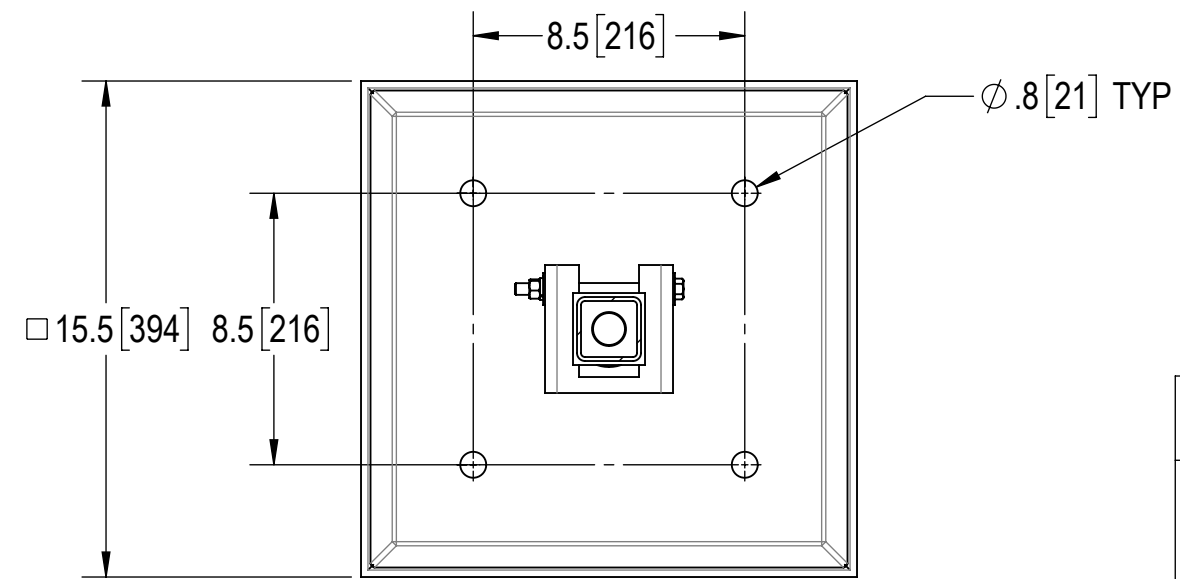

SECTION F-F
SCALE 1 : 6

HIDE BAR GRATING FOR CLARITY

COMMSCOPE, INC. OF NORTH CAROLINA			
TITLE EQUIPMENT PLATFORM 10' X 12' W/ 6 AL			
SIZE C	SCALE 1:24	DOCUMENT NO. EQ-P1012-AL	
		DRAWING	
		VERSION	STATUS
		01	RE
		REVISION	REVISION
			C
			SHEET 2 OF 2

4

3

2

1